



# C

## Rough Boring 粗镗加工用刀具

HBA Double Edge Rough Boring Tools HBA双刃粗镗刀 C007

HBH Large Diameter Rough Boring Tools HBH大直径粗镗刀 C013

TQC Rough Boring Tools TQC粗镗刀 C017

TZC Rough Boring Tools TZC粗镗刀 C021

## Finish Boring 精镗加工用刀具

SMB Small Micro-adjustable Fine Boring Tools SMB小孔径微调精镗刀 C027

HBM Micro-adjustable Fine Boring Tools HBM微调精镗刀 C033

MBQ Micro-adjustable Fine Boring Tools MBQ微调精镗刀 C037

HBH Large Diameter Fine Boring Tools HBH大直径精镗刀 C039

## Boring Unit 镗削单元

MB Micro-adjustable Fine Boring Unit MB微调精镗单元 C044

MAC Micro-adjustable Cartridge MAC微调小刀夹 C050

TQC Boring Head TQC镗刀头 C053

TZC Boring Head TZC镗刀头 C054

Indexable Cartridge 可转位小刀夹 C055

# C 孔加工刀具 Hole Making Tools

孔加工刀具

ROUGH BORING  
粗鏜用刀具

FINISH BORING  
精鏜用刀具

BORING UNIT  
镗削单元



# C 孔加工刀具 Hole Making Tools



HBA双刃粗镗刀  
镗孔范围19.8-224mm

C009



HBH大直径粗镗刀  
镗孔范围150-1060mm

C013



TQC粗镗刀  
镗孔范围25-190mm

C017



标准刀夹  
最小镗孔直径20mm

C055



TZC粗镗刀  
镗孔范围25-190mm

C021

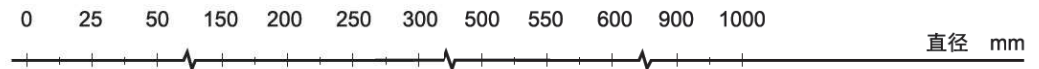

SMB小孔径微调精镗刀  
镗孔范围3-50mm

C027



MAC微调小刀夹  
最小镗孔直径28mm

C050



HBM微调精镗刀  
镗孔范围20-200mm

C033



MB微调精镗单元  
最小镗孔直径25.7mm

C044



MBQ微调精镗刀  
镗孔范围26-210mm

C037



HBH大直径微调精镗刀  
镗孔范围150-1060mm

C039

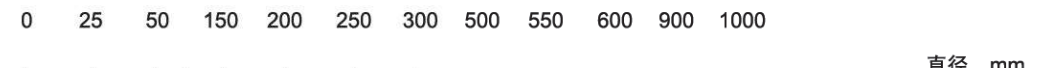

孔加工刀具

粗镗用刀具  
ROUGH BORING

精镗用刀具  
FINISH BORING

镗削单元  
BORING UNIT



# C 孔加工刀具 Hole Making Tools

kilowood模块式镗刀系统-自由组合成最适合的镗削刀具  
kilowood Modular Boring System

## 高精度、高刚性、高灵活性-镗削刀具连接方式

### 高刚性

内锥端螺钉、外锥端螺钉和滑销的锥形模块作用，使模块与主体紧固连接。可以进行粗镗等高扭矩加工。

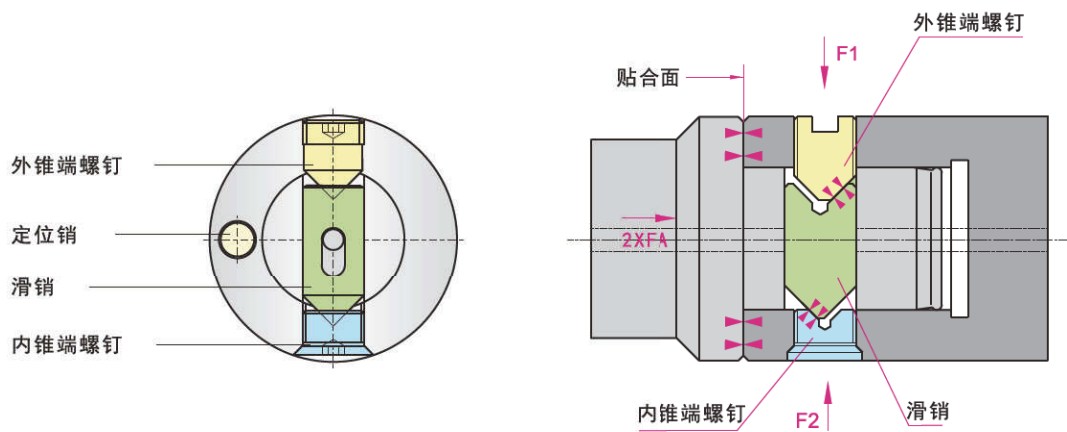

### 高灵活性

灵活设定加工直径和有效加工深度

针对不同的工件形状，可以使用等径中间模块加长或利用变径中间模块减小加工直径，保证刚性同时并防止刀具干涉。

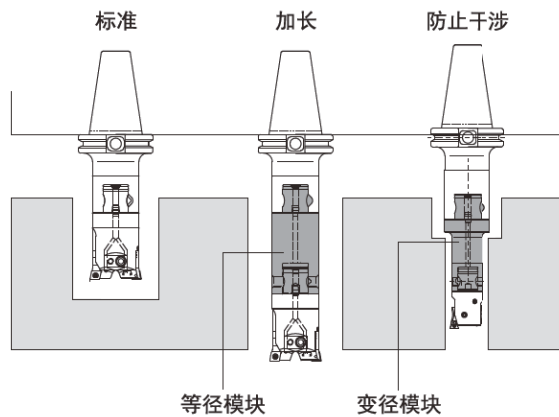

### 高精度

重复连接精度2-3um, 同一镗刀工作模块多次重复装、拆。刀尖位置误差不超过3um, 从而保证获得稳定的加工精度。

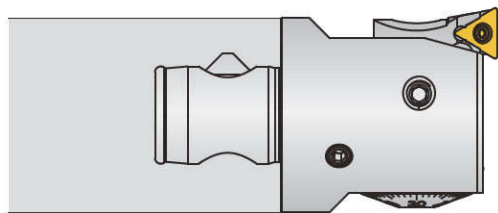

# C 孔加工刀具 Hole Making Tools

kilowood模块式镗刀系统-自由组合成最适合的镗削刀具  
 kilowood Modular Boring System



## 工作模块 功能多样的工作模块，完成各种孔加工。

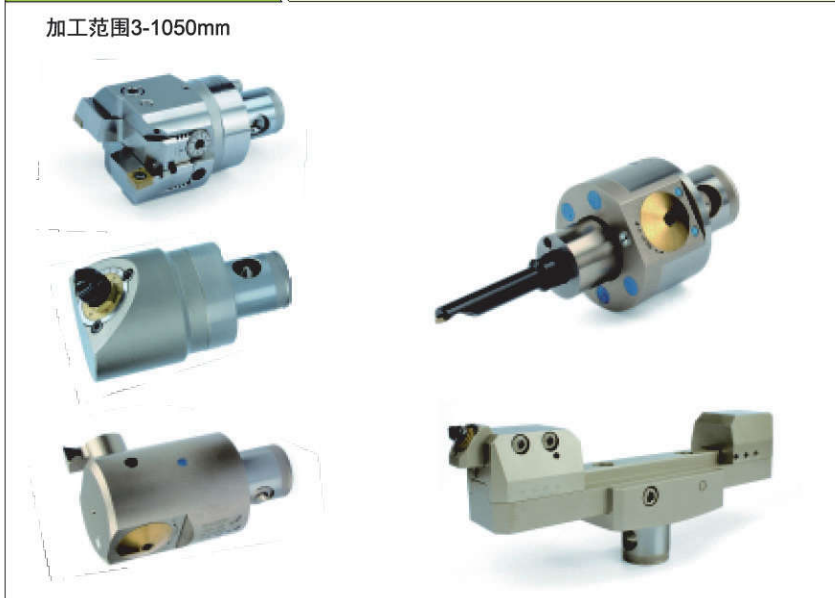

## 中间模块 规格齐全的中间模块，加长刀柄或防干涉。



## 主柄模块 针对各种主轴接口的各种主柄模块

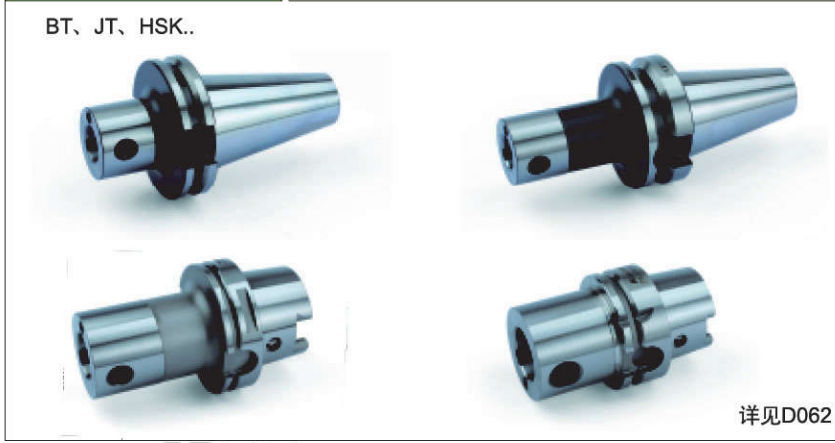

孔加工刀具  
 粗镗用刀具  
 精镗用刀具  
 镗削单元

# C 孔加工刀具 Hole Making Tools

HBA双刃镗刀  
HBA Double Edge Rough Boring Tools

镗孔范围：  $\phi 19.8 \sim \phi 224\text{mm}$   
TMG21高刚性接口、螺纹接口、侧固式接口

## 高刚性

刀体和刀头采用齿纹平面配合，压紧后双面贴合，确保刀体与镗刀头之间高刚性连接，从而可承担更大载荷的切削。

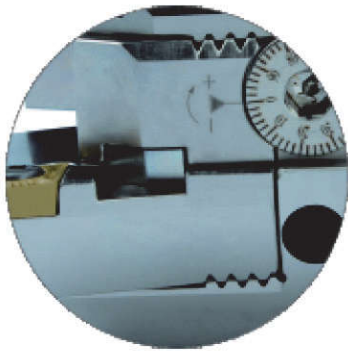

## 高效调节

特别设计的粗调机构，集粗镗与半精镗加工于一体。双向可调，粗加工时无需使用刀调仪对刀；调节精度每格  $\phi 0.05\text{mm}$ ，可用于孔的半精镗加工。

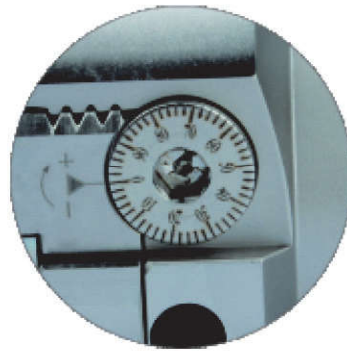

## 加工方式多样

使用方式多样，可实现双刃、单刃、锯齿镗削和半精镗削加工。采用CCMT1204刀片锯齿镗削时，可以一次镗削扩孔高达32mm

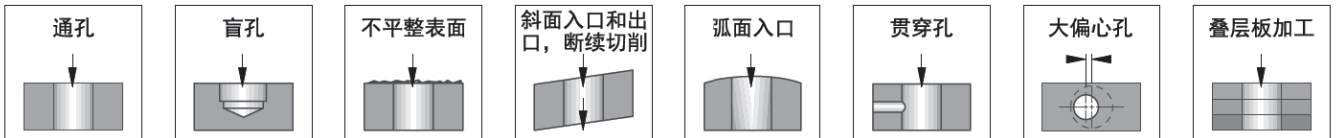

## 独特刀头内冷设计

镗刀头内冷设计，有利于刀尖冷却，提高刀具使用寿命。

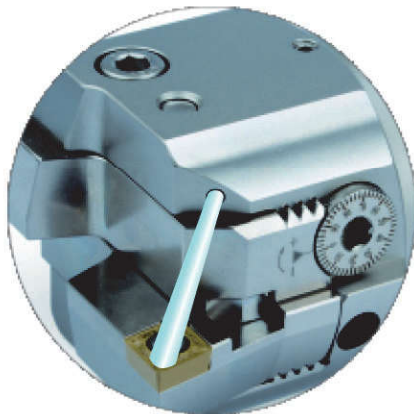

# C 孔加工刀具 Hole Making Tools

## 镗刀头定制

## Custom boring head

可根据用户要求用户定制镗刀头

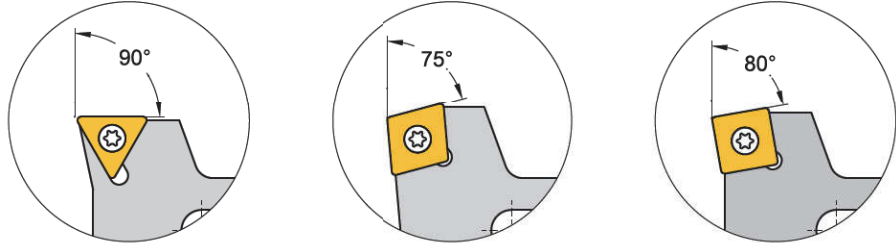

## 注意

由于排屑原因当加工直径接近刀具镗孔 $d_c$ 下限时，请减少单边加工余量 $ap$ 来达到最佳切削效果

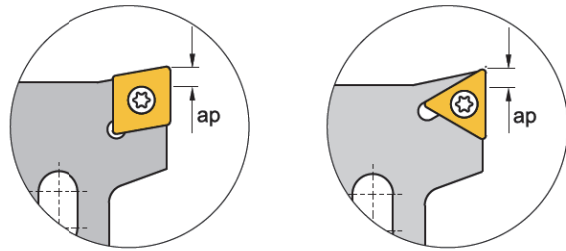

## 调节方法

1. 松开锁紧螺钉1，保持一定的预紧力
2. 旋转调节螺钉2，设定到目标直径
3. 在另一侧重复步骤1和步骤2
4. 拧紧锁紧螺钉1
5. 将双刃镗刀安装在主柄模块上，注意保证端面贴合

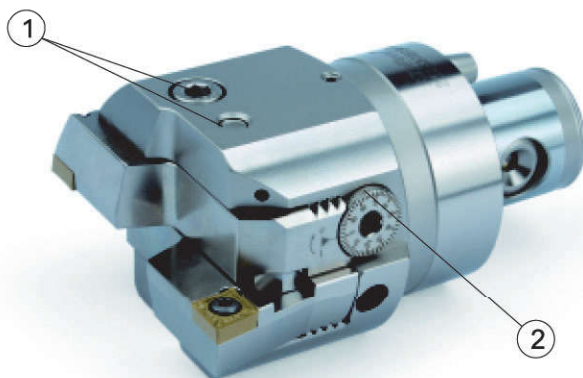

# C 孔加工刀具 Hole Making Tools

## HBA双刃粗镗刀

## HBA Double Edge Rough Boring Tools



型式 I

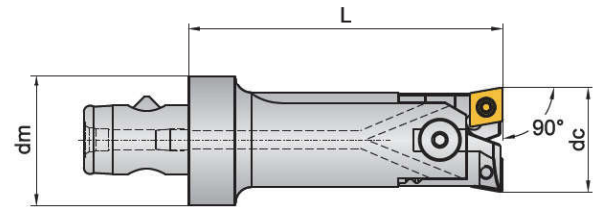

型式 II

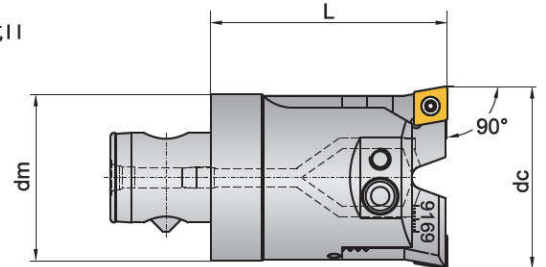

孔加工刀具

ROUGH BORING  
粗镗用刀具

FINISH BORING  
精镗用刀具

BORING UNIT  
镗削单元

刀片 Inserts	螺钉 Screw	扳手 Wrench
CC..060204	SIC025065	FT07
CC..09T308	SIC035080	FT15
CC..120408	SID040110	FT15



型号 Type	库存 Stock	柄部型式 Module size	尺寸(mm) Dimension			镗刀头 Boring head	刀片 Inserts	型式 Model	重量 (kg)
			dc	dm	L				
21CD25-HBA20-60	●	21CD25	19.8~27	25	60	HBA20	CC..060204	I	0.14
21CD25-HBA27-50	●	21CD25	27~36	25	50	HBA27	CC..060204	II	0.18
21CD32-HBA35-60	●	21CD32	35~45	32	60	HBA35	CC..060204	II	0.34
21CD40-HBA44-70	●	21CD40	44~56	40	70	HBA44	CC..09T308	II	0.60
21CD50-HBA55-80	●	21CD50	55~71	50	80	HBA55	CC..120408	II	1.06
21CD63-HBA69-90	●	21CD63	69~91	63	90	HBA69	CC..120408	II	1.93
21CD63-HBA90-100	●	21CD63	90~122	63	100	HBA90	CC..120408	II	2.66
21CD80-HBA90-100	●	21CD80	90~122	80	100	HBA90	CC..120408	II	3.49
21CD63-HBA120-100D	●	21CD63	120~162	63	100	HB120D	CC..120408	II	3.76
21CD80-HBA120-100D	●	21CD80	120~162	80	100	HB120D	CC..120408	II	4.47
21CD100-HBA160-100D	●	21CD100	160~224	100	100	HB160D	CC..120408	II	7.32

● 常备库存  
Unallocated stock

◐ 可备库存  
Available stock

○ 订单生产  
Order production



# C 孔加工刀具 Hole Making Tools

## HBA双刃粗镗刀

## HBA Double Edge Rough Boring Tools



型式I

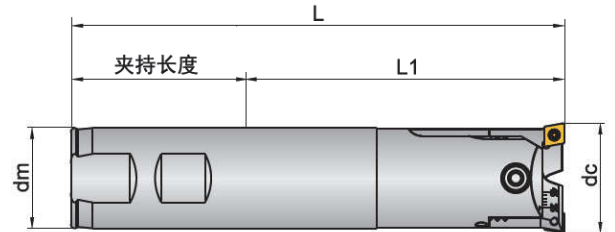

型式II

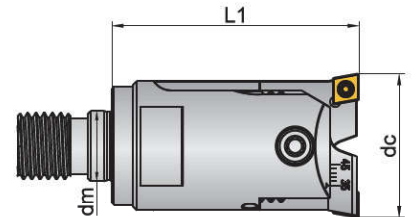

刀片 Inserts	螺钉 Screw	扳手 Wrench
CC..060204	SIC025065	FT07
CC..09T308	SIC035080	FT15

型号 Type	库存 Stock	柄部型式 Holder size	尺寸(mm) Dimension				镗刀头 Boring head	刀片 Inserts	型式 Model	重量 (kg)
			dc	dm	L1	L				
B20-HBA20-80	●	B20	19.8~27	20	80	130	HBA20	CC..060204	I	0.28
B25-HBA27-100	●	B25	27~36	25	100	156	HBA27	CC..060204	I	0.56
B32-HBA35-125	●	B32	35~45	32	125	185	HBA35	CC..060204	I	1.09
B40-HBA44-160	●	B40	44~56	40	160	230	HBA44	CC..09T308	I	2.11
DM10-HBA20-60	●	DM10	19.8~27	10.5	60	-	HBA20	CC..060204	II	0.11
DM12-HBA27-50	●	DM12	27~36	12.5	50	-	HBA27	CC..060204	II	0.16
DM16-HBA35-60	●	DM16	35~45	17	60	-	HBA35	CC..060204	II	0.32
DM16-HBA44-70	●	DM16	44~56	17	70	-	HBA44	CC..09T308	II	0.54

● 常备库存  
Unallocated stock

◐ 可备库存  
Available stock

○ 订单生产  
Order production

# C 孔加工刀具 Hole Making Tools

## HBA双刃粗镗刀

## HBA Double Edge Rough Boring Tools

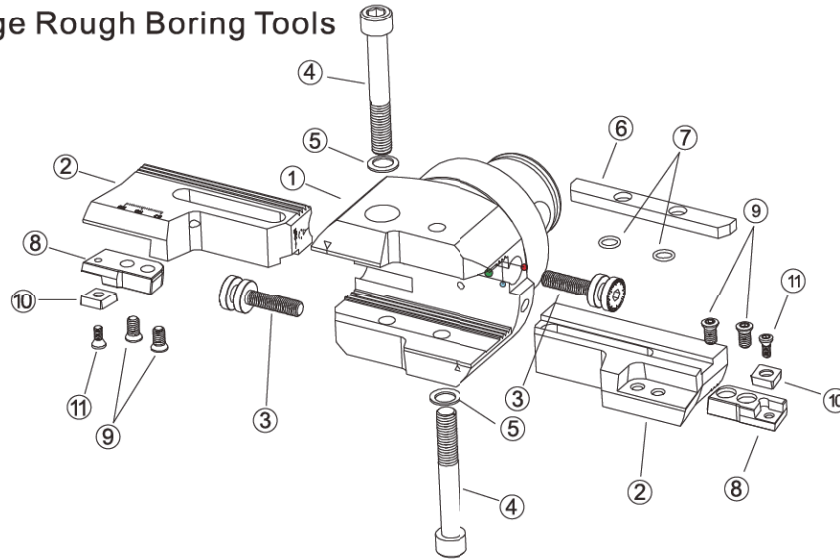

型号 Type	②镗刀头 Boring head	③微调螺钉 Adjusting screw	④压紧螺钉 Clamping screw	⑤弹簧垫圈 Spring washer	⑥垫块 Location block
....-HBA20-....	HBA20	SSC030050	SIC040160AB	-	HB20-DK
....-HBA27-....	HBA27	HBMS-0	SCC040200	TD04	-
....-HBA35-....	HBA35	HBMS-1	SCC050250	TD05	-
....-HBA44-....	HBA44	HBMS-1	SCC060320	TD06	-
....-HBA55-....	HBA55	HBMS-2	SCC080400	TD08	-
....-HBA69-....	HBA69	HBMS-2	SCC080450	TD08	HB69-DK
....-HBA90-....	HBA90	HBMS-3	SCC080600	TD08	HB90-DK
....-HBA120-....	HB120D	HBMS-3	SCC100650	TD10	HB120-DK
....-HBA160-....	HB160D	HBMS-3	SCC120750	TD12	HB160-DK

型号 Type	⑦垫圈 Sealer	⑧小刀夹 Cartridge	⑨压紧螺钉 Clamping screw	⑩刀片 Insert	⑪刀片螺钉 Insert screw
....-HBA20-....	-	-	-	CC..060204	SIC025065
....-HBA27-....	-	-	-	CC..060204	SIC025065
....-HBA35-....	-	-	-	CC..060204	SIC025065
....-HBA44-....	-	-	-	CC..09T308	SIC035080
....-HBA55-....	-	-	-	CC..120408	SID040110
....-HBA69-....	HB69/90-DR	-	-	CC..120408	SID040110
....-HBA90-....	HB69/90-DR	-	-	CC..120408	SID040110
....-HBA120-....	HB120-DR	SCFCR12CA-HBA	SCC060120	CC..120408	SID040110
....-HBA160-....	HB160-DR	SCFCR12CA-HBA	SCC060120	CC..120408	SID040110

# C 孔加工刀具 Hole Making Tools

## HBA双刃粗镗刀

## HBA Double Edge Rough Boring Tools

### 加工示例

使用刀具	21CD63-HBA63-90
使用刀片	CCMT120408-UM CPT25
加工材料	45#
材料硬度	300HB
加工深度	60mm
镗孔直径	70mm
机床接口	BT40
切削液	水溶液

切削速度 $V_c$	154 m/min
主轴转速 $n$	700 r/min
进给速度 $F$	210 mm/min
每齿进给 $F_z$	0.15 mm/z
切削深度 $a_p$	5 mm



### HBA双刃镗刀使用说明

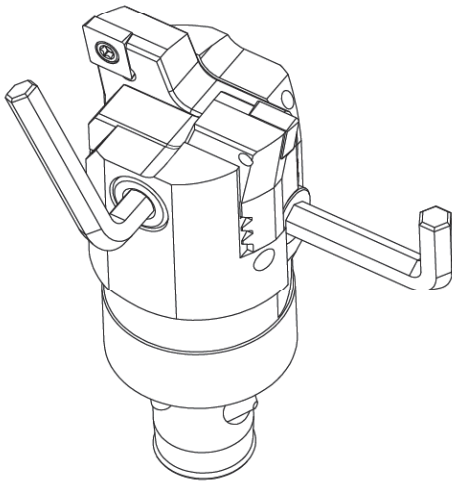

- 安装前须将各配合面（包括：主体齿纹槽，主体调节螺钉孔及接口部分）清理干净，不得有粉尘、铁屑等残留。否则可能会导致刀具不能有效夹持，调节不够平滑，甚至划伤配合面。
- 刀具使用前应确保已充分夹紧，各配合面贴合紧密无间隙（可采用塞尺、透光等方法检验）必要时可使用加力杆。
- 调节尺寸前应有必要的预紧力，刀头滑动松紧适度，以避免夹紧后尺寸发生变化。
- 刀具预调时应保证有较好的径向跳动，以获得预期的表面粗糙度（一般应控制在0.05mm内）。
- 为获得理想的轴向跳动，所有刀头均需成对更换。
- 立式加工中心加工较深孔时建议采用高压内冷，以获得较好的排屑效果。

# C 孔加工刀具 Hole Making Tools

HBH大直径粗镗刀

HBH Large Diameter Rough Boring Tools



型式 I

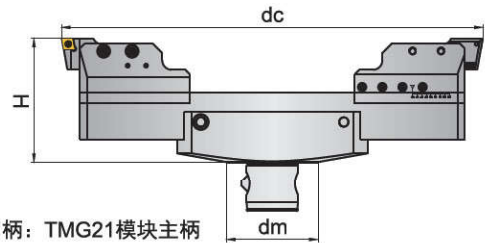

适用刀柄: TMG21模块主柄



型式 II

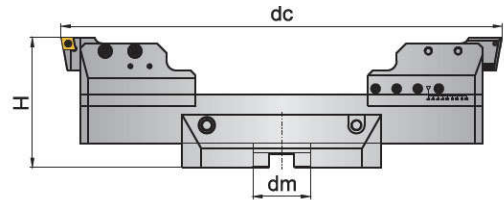

适用刀柄: 面铣刀刀柄



孔加工刀具

ROUGH BORING  
粗镗用刀具

FINISH BORING  
精镗用刀具

BORING UNIT  
镗削单元

刀片 Inserts	螺钉 Screw 	扳手 Wrench 
CC..120408	SID040110	FT15

型号 Type	库存 Stock	尺寸(mm) Dimension			刀片 Inserts 	型式 Model	重量 (kg)
		dc	dm	H			
21CD63-HBH150	●	Φ 150~Φ 215	63	85	CC..120408	I	3.70
S32-HBH150	●	Φ 150~Φ 215	32	110	CC..120408	II	4.44
21CD63-HBH215	●	Φ 215~Φ 280	63	85	CC..120408	I	4.29
S32-HBH215	●	Φ 215~Φ 280	32	110	CC..120408	II	5.03
21CD80-HBH280	●	Φ 280~Φ 370	80	95	CC..120408	I	7.58
T40-HBH280	●	Φ 280~Φ 370	40	95	CC..120408	II	7.49
21CD80-HBH370	●	Φ 370~Φ 460	80	95	CC..120408	I	8.44
T40-HBH370	●	Φ 370~Φ 460	40	95	CC..120408	II	8.35
21CD100-HBH460AL	◐	Φ 460~Φ 580	100	150	CC..120408	I	17.54
T60-HBH460AL	◐	Φ 460~Φ 580	60	150	CC..120408	II	17.13
21CD100-HBH580AL	◐	Φ 580~Φ 700	100	155	CC..120408	I	19.77
T60-HBH580AL	◐	Φ 580~Φ 700	60	155	CC..120408	II	18.76
21CD100-HBH700AL	◐	Φ 700~Φ 820	100	160	CC..120408	I	22.22
T60-HBH700AL	◐	Φ 700~Φ 820	60	160	CC..120408	II	21.81
21CD100-HBH820AL	◐	Φ 820~Φ 940	100	165	CC..120408	I	25.72
T60-HBH820AL	◐	Φ 820~Φ 940	60	165	CC..120408	II	25.31
21CD100-HBH940AL	◐	Φ 940~Φ 1060	100	170	CC..120408	I	27.77
T60-HBH940AL	◐	Φ 940~Φ 1060	60	170	CC..120408	II	27.36

● 常备库存  
Unallocated stock

◐ 可备库存  
Available stock

○ 订单生产  
Order production

# C 孔加工刀具 Hole Making Tools

## 面铣刀接柄大直径镗刀安装说明

Direction for installation of large diameter boring tools with face mill connector

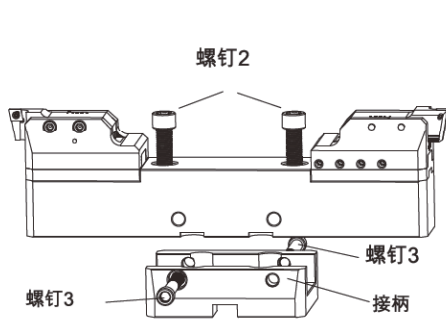

1. 松开螺钉2和螺钉3，卸下接柄。

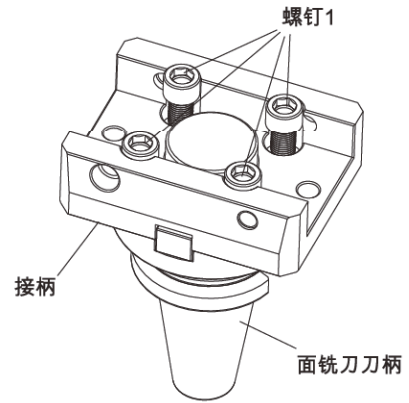

2. 清理要贴合的面，将接柄装入面铣刀刀柄，锁紧螺钉1

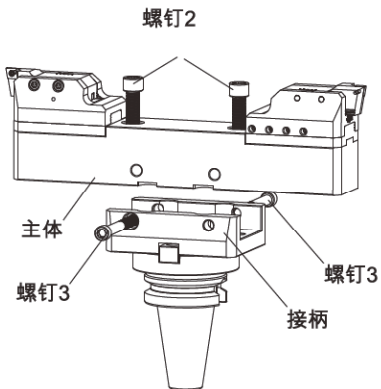

3. 清理要贴合的面，将主体装入接柄中，锁紧螺钉2和螺钉3。

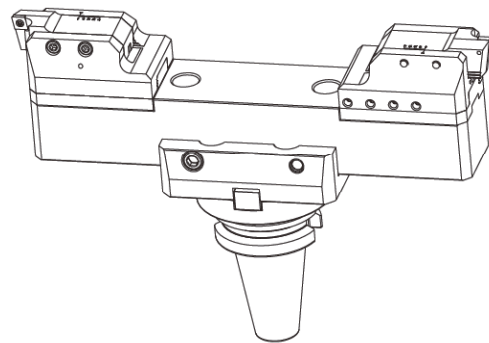

4. 完成安装。

镗刀头灵活定制，可根据客户加工需求定制不同主偏角刀头，可针对客户具体加工状况制作特殊功能刀头。  
下图为插补铣端面锥度圆弧槽定制刀头刀具。

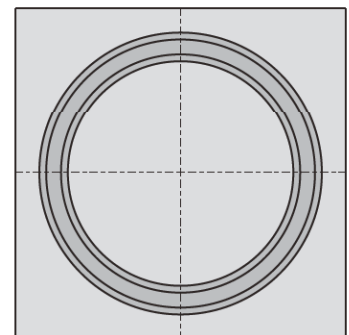
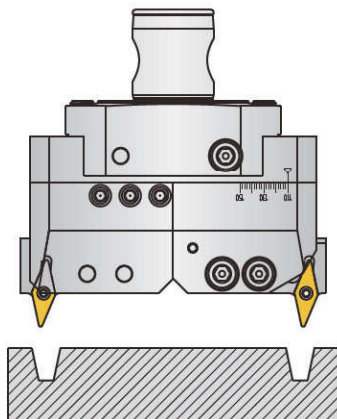



# C 孔加工刀具 Hole Making Tools

HBH大直径粗镗刀

HBH Large Diameter Rough Boring Tools

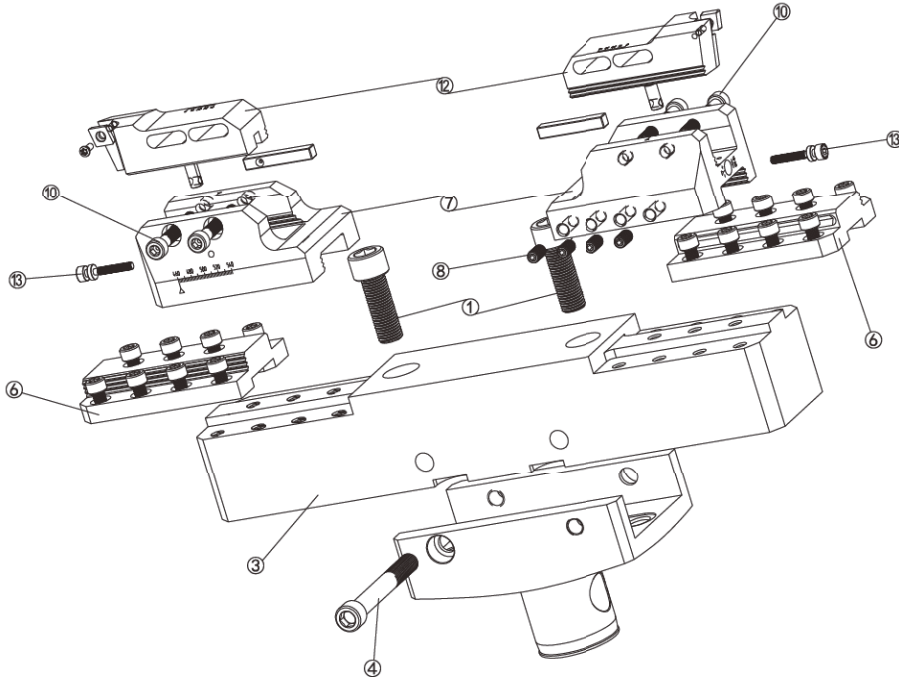







接柄 Connection holder	①螺钉 Screw	②扳手 Wrench	③主体 Body	④螺钉 Screw	⑤扳手 Wrench	⑥连接块 Connection block	⑦刀座 Supporting chasis
21CD63-HBH	SCC080300	S6	HBH150	SCC080600	S8	-	HBH-65Z
S32-HBH				SCC080700			
21CD63-HBH			SCC080600				
S32-HBH			SCC080700				
21CD80-HBH	SCC120350	S10	HBH280	SCC100750	S8	-	HBH-90Z
T40-HBH				SCC100850			
21CD80-HBH			SCC100750				
T40-HBH			SCC100850				
21CD100-HBH	SCC160450	S14	HBH460AL	SCC120950	S10	HBH-120S	HBH-120Z
T60-HBH				SCC1201100			
21CD100-HBH			HBH580AL	SCC120950			
T60-HBH				SCC1201100			
21CD100-HBH			HBH700AL	SCC120950			
T60-HBH				SCC1201100			
21CD100-HBH			HBH820AL	SCC120950			
T60-HBH				SCC1201100			
21CD100-HBH			HBH940AL	SCC120950			
T60-HBH				SCC1201100			

# C 孔加工刀具 Hole Making Tools

HBH大直径粗镗刀

HBH Large Diameter Rough Boring Tools



接柄 Connection holder	⑧螺钉 Screw 	⑨扳手 Wrench 	⑩螺钉 Screw 	⑪扳手 Wrench 	⑫粗镗刀头 Rough head 	⑬微调螺钉 Adjusting screw 
21CD63-HBH	SZC080160	S4	SCC080350		HBH-65R	HBMS-2-28
S32-HBH					HBH-90R	
21CD63-HBH			SCC080400		HBH-90R	
S32-HBH						
21CD80-HBH			SCC080500		HBH-120R	
T40-HBH						
21CD80-HBH						
T40-HBH						
21CD100-HBH						
T60-HBH						
21CD100-HBH						
T60-HBH						
21CD100-HBH						
T60-HBH						
21CD100-HBH						
T60-HBH						
21CD100-HBH						
T60-HBH						

# C 孔加工刀具 Hole Making Tools

TQC粗镗刀-BT40

TQC Rough Boring Tools-BT40

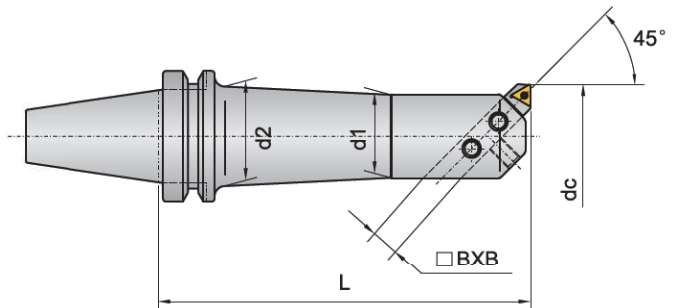
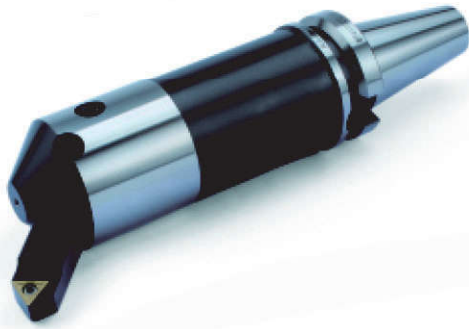

孔加工刀具

ROUGH BORING  
粗镗用刀具

FINISH BORING  
精镗用刀具

BORING UNIT  
镗削单元

型号 Type	库存 Stock	锥柄型式 Taper type	尺寸(mm) Dimension					螺钉 Screw	扳手 Wrench	重量 (kg)
			dc	d1	d2	B	L			
BT40-TQC25-135	●	BT40	25~38	20	24	8	135	SSC040050	S2	1.26
BT40-TQC30-165	●	BT40	30~42	24	28	8	165	SSC050060	S2.5	1.55
BT40-TQC38-180	●	BT40	38~52	30	36	10	180	SSC060080	S3	1.90
BT40-TQC42-210	●	BT40	42~56	34	40	10	210	SSC060080	S3	2.65
BT40-TQC50-180	●	BT40	50~65	40	48	13	180	SSC080120	S4	2.55
-225	◐	BT40	50~65	40	48	13	225	SSC080120	S4	3.40
BT40-TQC62-180	●	BT40	62~90	50	60	16	180	SSC100120	S5	3.45
-240	◐	BT40	62~90	50	60	16	240	SSC100120	S5	5.50
BT40-TQC72-180	●	BT40	72~110	60	60	19	180	SSC120160	S6	3.85
-240	●	BT40	72~110	60	60	19	240	SSC120160	S6	5.15
BT40-TQC90-180	◐	BT40	90~125	75	60	19	180	SSC120160	S6	3.07
-225	◐	BT40	90~125	75	60	19	225	SSC120160	S6	4.68

● 常备库存  
Unallocated stock

◐ 可备库存  
Available stock

○ 订单生产  
Order production

# C 孔加工刀具 Hole Making Tools

TQC粗镗刀-BT50

TQC Rough Boring Tools-BT50

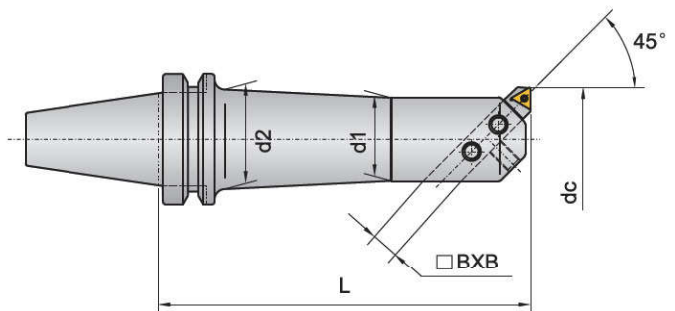

型号 Type	库存 Stock	锥柄型式 Taper type	尺寸(mm) Dimension					螺钉 Screw	扳手 Wrench	重量 (kg)
			dc	d1	d2	B	L			
BT50-TQC25-135	●	BT50	25~38	20	24	8	135	SSC040050	S2	5.39
BT50-TQC30-165	◐	BT50	30~42	24	28	8	165	SSC050060	S2.5	5.95
BT50-TQC38-180	●	BT50	38~52	30	36	10	180	SSC060080	S3	7.38
BT50-TQC42-210	●	BT50	42~56	34	40	10	210	SSC060080	S3	6.85
BT50-TQC50-180	●	BT50	50~65	40	48	13	180	SSC080120	S4	9.23
-240	●	BT50	50~65	40	48	13	240	SSC080120	S4	6.15
BT50-TQC62-195	●	BT50	62~90	50	60	16	195	SSC100120	S5	13.25
-270	●	BT50	62~90	50	60	16	270	SSC100120	S5	10.43
BT50-TQC72-195	●	BT50	72~110	60	70	19	195	SSC120160	S6	14.09
-285	●	BT50	72~110	60	70	19	285	SSC120160	S6	9.30
BT50-TQC90-210	●	BT50	90~125	75	80	19	210	SSC120160	S6	10.25
-300	◐	BT50	90~125	75	80	19	300	SSC120160	S6	13.50
BT50-TQC115-220	◐	BT50	115~190	100	80	25	220	SSC160160	S8	11.55
-300	◐	BT50	115~190	100	80	25	300	SSC160160	S8	12.40

● 常备库存  
Unallocated stock

◐ 可备库存  
Available stock

○ 订单生产  
Order production

# C 孔加工刀具 Hole Making Tools

TQC粗镗刀-JT40

TQC Rough Boring Tools-JT40

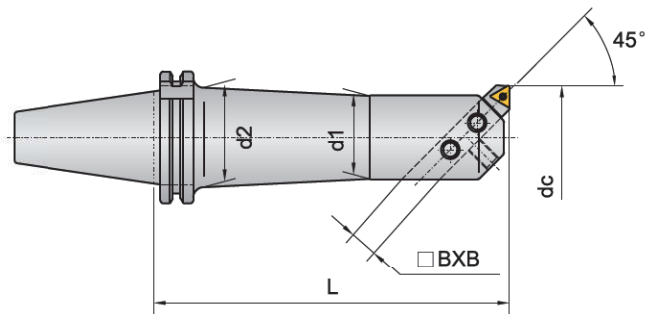

孔加工刀具

ROUGH BORING  
粗镗用刀具

FINISH BORING  
精镗用刀具

BORING UNIT  
镗削单元

型号 Type	库存 Stock	锥柄型式 Taper type	尺寸(mm) Dimension					螺钉 Screw	扳手 Wrench	重量 (kg)
			dc	d1	d2	B	L			
JT40-TQC25-135	○	JT40	25~38	20	24	8	135	SSC040050	S2	1.91
JT40-TQC30-165	○	JT40	30~42	24	28	8	165	SSC050060	S2.5	2.20
JT40-TQC38-180	●	JT40	38~52	30	36	10	180	SSC060080	S3	2.66
JT40-TQC42-210	○	JT40	42~56	34	40	10	210	SSC060080	S3	2.25
JT40-TQC50-180	○	JT40	50~65	40	48	13	180	SSC080120	S4	2.45
-225	○	JT40	50~65	40	48	13	225	SSC080120	S4	2.50
JT40-TQC62-180	○	JT40	62~90	50	50	16	180	SSC100120	S5	3.40
-240	○	JT40	62~90	50	50	16	240	SSC100120	S5	3.90
JT40-TQC72-180	○	JT40	72~110	60	50	19	180	SSC120160	S6	3.00
-240	○	JT40	72~110	60	50	19	240	SSC120160	S6	4.35
JT40-TQC90-180	○	JT40	90~125	75	50	19	180	SSC120160	S6	3.07
-225	○	JT40	90~125	75	50	19	225	SSC120160	S6	4.68

● 常备库存  
Unallocated stock

● 可备库存  
Available stock

○ 订单生产  
Order production



# C 孔加工刀具 Hole Making Tools

TQC粗镗刀-JT50

TQC Rough Boring Tools-JT50

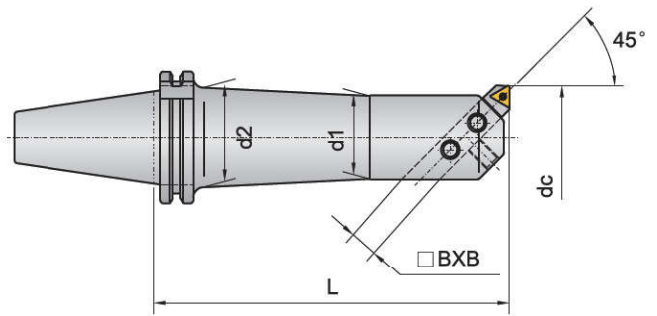

型号 Type	库存 Stock	锥柄型式 Taper type	尺寸(mm) Dimension					螺钉 Screw	扳手 Wrench	重量 (kg)
			dc	d1	d2	B	L			
JT50-TQC25-135	●	JT50	25~38	20	24	8	135	SSC040050	S2	5.39
JT50-TQC30-165	●	JT50	30~42	24	28	8	165	SSC050060	S2.5	5.95
JT50-TQC38-180	●	JT50	38~52	30	36	10	180	SSC060080	S3	7.38
JT50-TQC42-210	○	JT50	42~56	34	40	10	210	SSC060080	S3	6.85
JT50-TQC50-180	●	JT50	50~65	40	48	13	180	SSC080120	S4	9.23
-240	●	JT50	50~65	40	48	13	240	SSC080120	S4	6.15
JT50-TQC62-195	●	JT50	62~90	50	60	16	195	SSC100120	S5	13.25
-270	●	JT50	62~90	50	60	16	270	SSC100120	S5	10.43
JT50-TQC72-195	○	JT50	72~110	60	70	19	195	SSC120160	S6	14.09
-285	●	JT50	72~110	60	70	19	285	SSC120160	S6	9.30
JT50-TQC90-210	●	JT50	90~125	75	80	19	210	SSC120160	S6	10.25
-300	●	JT50	90~125	75	80	19	300	SSC120160	S6	13.50
JT50-TQC115-220	○	JT50	115~190	100	80	25	220	SSC160160	S8	10.50
-300	○	JT50	115~190	100	80	25	300	SSC160160	S8	11.35

● 常备库存  
Unallocated stock

● 可备库存  
Available stock

○ 订单生产  
Order production

# C 孔加工刀具 Hole Making Tools

TZC粗镗刀-BT40

TZC Rough Boring Tools-BT40

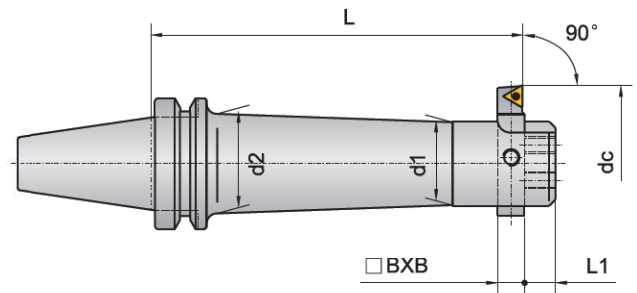

C054

型号 Type	库存 Stock	锥柄型式 Taper type	尺寸(mm) Dimension						螺钉 Screw	扳手 Wrench	重量 (kg)
			dc	d1	d2	B	L1	L			
BT40-TZC25-135	●	BT40	25~50	20	24	8	10	135	SSC040050	S2	1.30
BT40-TZC38-180	●	BT40	38~70	30	36	10	12	180	SSC060080	S3	2.05
BT40-TZC50-180	●	BT40	50~90	40	48	13	14	180	SSC080120	S4	2.85
-225	●	BT40	50~90	40	48	13	14	225	SSC080120	S4	3.37
BT40-TZC62-180	●	BT40	62~115	50	60	16	16	180	SSC100120	S5	3.81
-225	●	BT40	62~115	50	60	16	16	225	SSC100120	S5	4.64
BT40-TZC72-180	●	BT40	72~135	60	60	19	18	180	SSC120160	S6	4.41
-225	●	BT40	72~135	60	60	19	18	225	SSC120160	S6	5.52
BT40-TZC90-180	●	BT40	90~150	75	60	19	18	180	SSC120160	S6	5.23
-225	●	BT40	90~150	75	60	19	18	225	SSC120160	S6	6.24

● 常备库存

Unallocated stock

● 可备库存

Available stock

○ 订单生产

Order production

# C 孔加工刀具 Hole Making Tools

TZC粗镗刀-BT50

TZC Rough Boring Tools-BT50

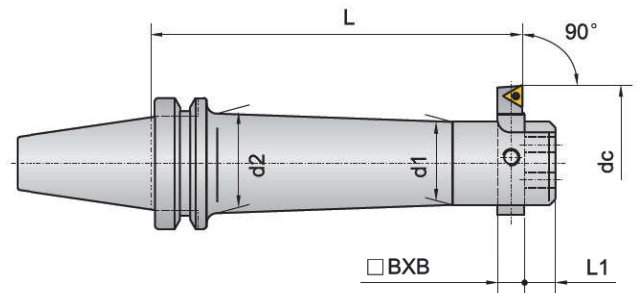

型号 Type	库存 Stock	锥柄型式 Taper type	尺寸(mm) Dimension						螺钉 Screw	扳手 Wrench	重量 (kg)
			dc	d1	d2	B	L1	L			
BT50-TZC25-135	●	BT50	25~50	20	24	8	10	135	SSC040050	S2	3.97
BT50-TZC38-180	●	BT50	38~70	30	36	10	12	180	SSC060080	S3	4.78
BT50-TZC50-180	●	BT50	50~90	40	48	13	14	180	SSC080120	S4	5.40
-240	●	BT50	50~90	40	48	13	14	240	SSC080120	S4	6.06
BT50-TZC62-195	●	BT50	62~115	50	60	16	16	195	SSC100120	S5	6.29
-270	●	BT50	62~115	50	60	16	16	270	SSC100120	S5	8.28
BT50-TZC72-195	●	BT50	72~135	60	70	19	18	195	SSC120160	S6	7.75
-285	●	BT50	72~135	60	70	19	18	285	SSC120160	S6	10.12
BT50-TZC90-210	●	BT50	90~150	75	80	19	18	210	SSC120160	S6	10.24
-300	●	BT50	90~150	75	80	19	18	300	SSC120160	S6	14.15
BT50-TZC105-195	●	BT50	105~190	90	80	25	20	195	SSC160160	S8	11.33
-285	●	BT50	105~190	90	80	25	20	285	SSC160160	S8	14.26

● 常备库存 Unallocated stock    ● 可备库存 Available stock    ○ 订单生产 Order production

# C 孔加工刀具 Hole Making Tools

TZC粗镗刀-JT40

TZC Rough Boring Tools-JT40

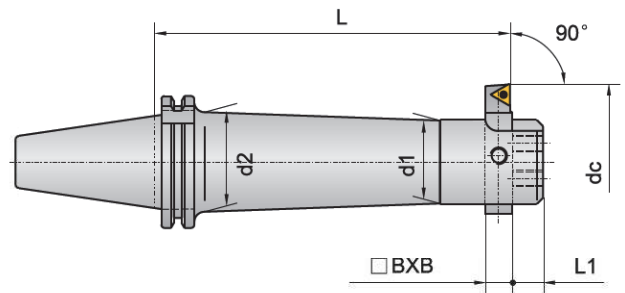

型号 Type	库存 Stock	锥柄型式 Taper type	尺寸(mm) Dimension						螺钉 Screw	扳手 Wrench	重量 (kg)
			dc	d1	d2	B	L1	L			
JT40-TZC25-135	●	JT40	25~50	20	24	8	10	135	SSC040050	S2	1.20
JT40-TZC38-180	●	JT40	38~70	30	36	10	12	180	SSC060080	S3	1.91
JT40-TZC50-180	●	JT40	50~90	40	48	13	14	180	SSC080120	S4	2.73
-225	○	JT40	50~90	40	48	13	14	225	SSC080120	S4	3.28
JT40-TZC62-180	○	JT40	62~115	50	50	16	16	180	SSC100120	S5	3.72
-225	○	JT40	62~115	50	50	16	16	225	SSC100120	S5	4.55
JT40-TZC72-180	○	JT40	72~135	60	50	19	18	180	SSC120160	S6	4.31
-225	○	JT40	72~135	60	50	19	18	225	SSC120160	S6	5.42
JT40-TZC90-180	●	JT40	90~150	75	50	19	18	180	SSC120160	S6	5.14
-225	○	JT40	90~150	75	50	19	18	225	SSC120160	S6	6.15

● 常备库存 Unallocated stock    ● 可备库存 Available stock    ○ 订单生产 Order production

# C 孔加工刀具 Hole Making Tools

TZC粗镗刀-JT50

TZC Rough Boring Tools-JT50

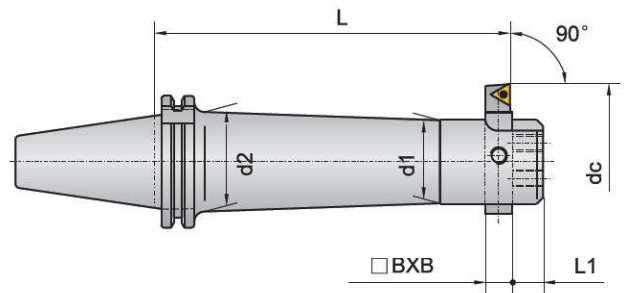
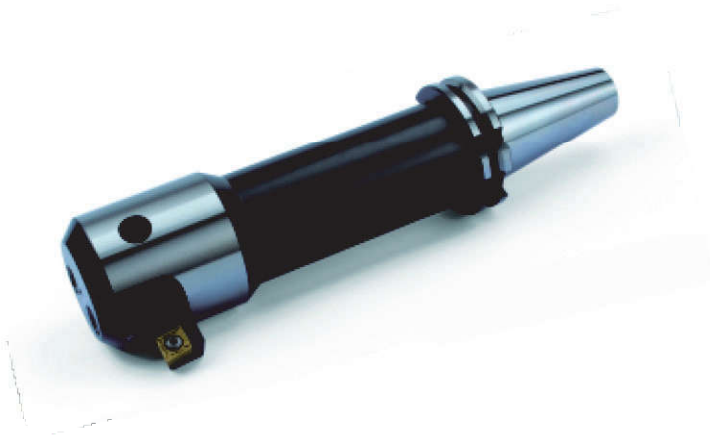

型号 Type	库存 Stock	锥柄型式 Taper type	尺寸(mm) Dimension						螺钉 Screw	扳手 Wrench	重量 (kg)
			dc	d1	d2	B	L1	L			
JT50-TZC25-135	●	JT50	25~50	20	24	8	10	135	SSC040050	S2	3.07
JT50-TZC38-180	●	JT50	38~70	30	36	10	12	180	SSC060080	S3	3.88
JT50-TZC50-180	●	JT50	50~90	40	48	13	14	180	SSC080120	S4	4.68
-240	●	JT50	50~90	40	48	13	14	240	SSC080120	S4	5.39
JT50-TZC62-195	●	JT50	62~115	50	60	16	16	195	SSC100120	S5	5.95
-270	●	JT50	62~115	50	60	16	16	270	SSC100120	S5	7.38
JT50-TZC72-195	●	JT50	72~135	60	70	19	18	195	SSC120160	S6	6.85
-285	●	JT50	72~135	60	70	19	18	285	SSC120160	S6	9.23
JT50-TZC90-210	●	JT50	90~150	75	80	19	18	210	SSC120160	S6	9.94
-300	●	JT50	90~150	75	80	19	18	300	SSC120160	S6	13.25
JT50-TZC105-195	●	JT50	105~190	90	80	25	20	195	SSC160160	S8	10.43
-285	●	JT50	105~190	90	80	25	20	285	SSC160160	S8	14.09

● 常备库存 Unallocated stock    ● 可备库存 Available stock    ○ 订单生产 Order production



# C 孔加工刀具 Hole Making Tools

TQC/TZC 技术资料  
TQC/TZC Technical Information

孔加工刀具

ROUGH BORING  
粗镗用刀具

FINISH BORING  
精镗用刀具

BORING UNIT  
镗削单元

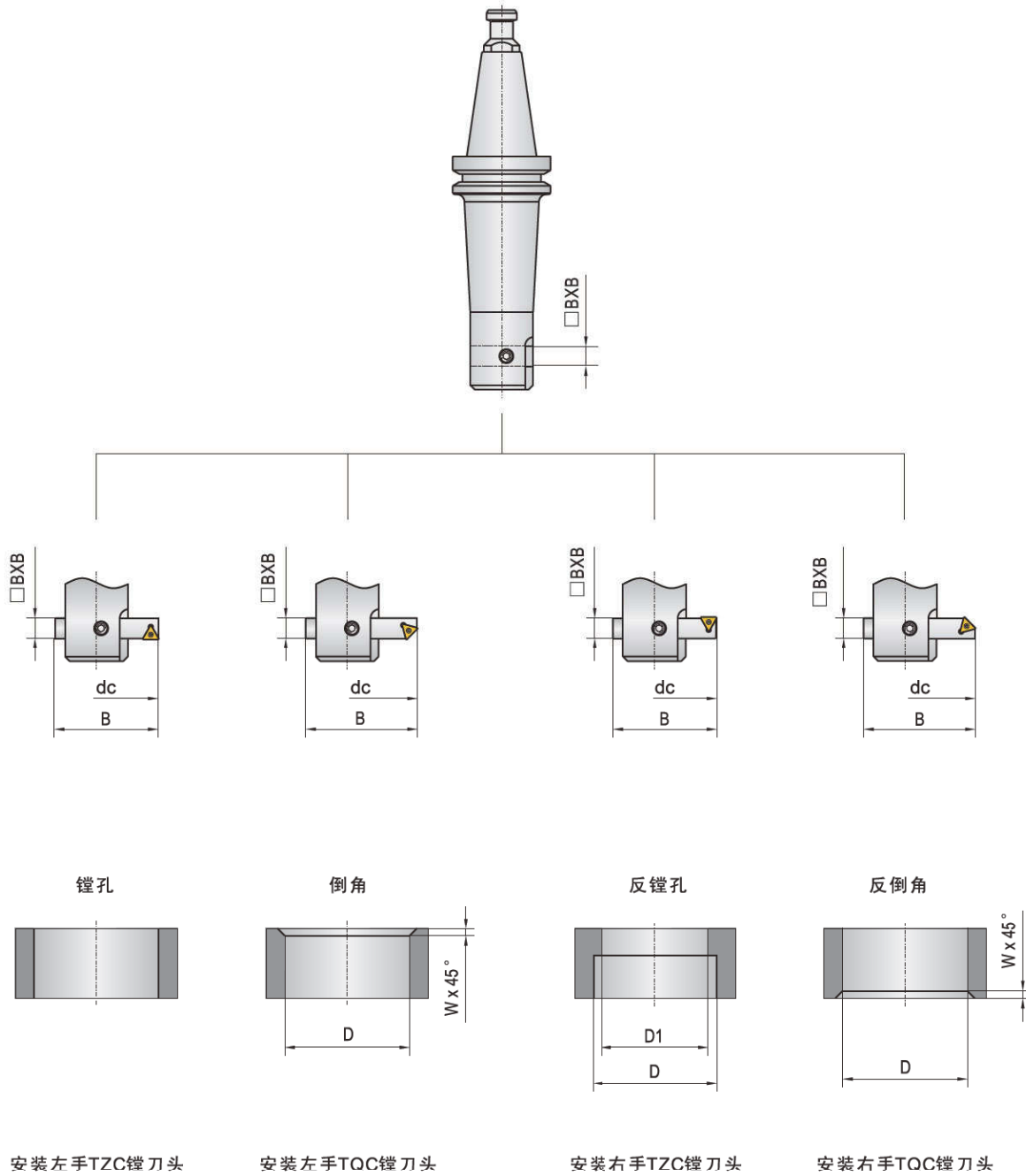

# C 孔加工刀具 Hole Making Tools

TQC/TZC 技术资料  
TQC/TZC Technical Information

直角型粗镗刀



通孔型

1. 常用于通孔加工/盲孔加工，采用大圆弧过渡增加其刚性。  
可根据加工需要选配相应TZC、TQC的镗刀头可完成镗孔，孔口倒角，反镗孔（倒角）。
2. 结构简单，调节范围较大。
3. 镗头价格便宜，易于更换，通用性较强
4. 单刃结构切削效率较低，标准结构不带内冷却孔，调节不带刻度需要在对刀仪上或采用打表的方式进行调节。

倾斜型粗镗刀



盲孔型

## 镗刀头 Rough boring head

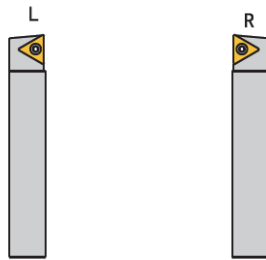

用于正向镗孔

用于反向镗孔

按旋向分左刀和右刀  
TQC镗刀头主偏角为45°  
TZC镗刀头主偏角为90°  
镗头有安装T型和C型刀片两种，  
后者可提高刀片刀尖强度，承担更大载荷的切削  
镗头可根据用户需求制造不同的主偏角

## TZC镗刀案例 Example of TZC boring tools

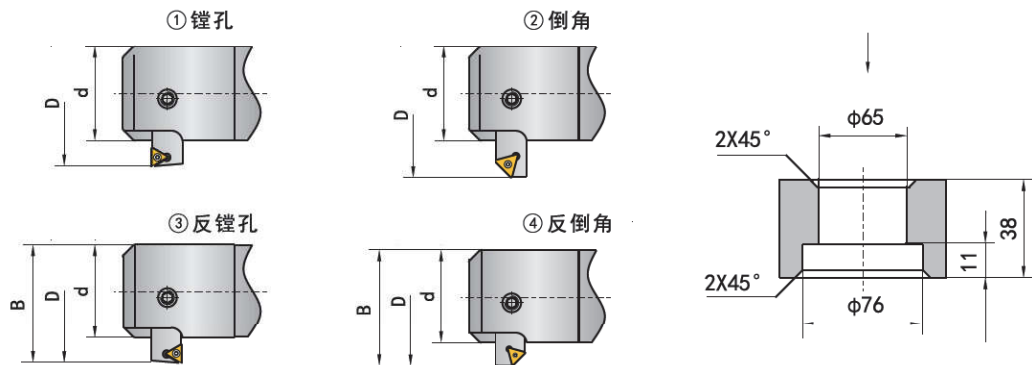

$$B = (D/2 + d/2) < \phi 65$$

注意镗刀杆的长度

# C 孔加工刀具 Hole Making Tools

## SMB小孔径微调精镗刀

## SMB Small Micro-adjustable Fine Boring Tools

完美解决  $\phi$  3-50小孔镗削问题

Perfect Solution for Boring Diameter  $\phi$  3-50

孔加工刀具

ROUGH BORING  
粗镗用刀具

FINISH BORING  
精镗用刀具

BORING UNIT  
镗削单元



径向最大调节行程5mm  
Max. Adjustment 5mm

### 多种镗杆可选

A wide choice of the boring bar

9种标准型号SBJ镗杆可选

可定制重钨合金SBJ镗杆

整体硬质合金镗杆最小镗孔直径可达  $\phi$  3mm

9 standard SBJ boring bar can be ordered

Boring bar with heavy alloy can be made

The minimum boring diameter can be 3mm by carbide boring bar

### 注油杯

Lubricator

独特内部润滑设计, 刀具调节更顺滑, 延长刀具使用寿命

Special design for inner lubricity makes Adjustment more smoothly, and prolong service life of tools

### 高精度微调机构

High accuracy adjustment machine

刻度盘刻度  $\phi$  0.01mm/格

单程调节精度  $\phi$  0.01mm/格

配合游标精度  $\phi$  0.001mm

The smallest graduation  $\phi$  0.01mm

Adjustment accuracy  $\phi$  0.01mm/div

Vernier accuracy  $\phi$  0.001mm

### TMG21模块化接口

TMG21 modular interface

可选配所有TMG21模块手柄

连接刚性好

重复定位精度高

All holder with same TMG21 interface can be selected

High rigidity interface

High re-setting accuracy

# C 孔加工刀具 Hole Making Tools

SMB小孔径微调精镗刀

SMB Small Micro-adjustable Fine Boring Tools

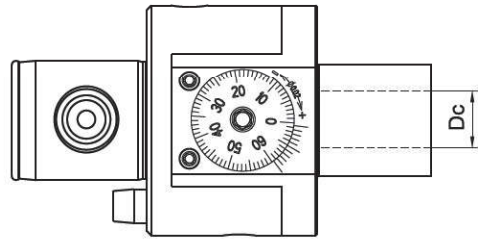

型号 Type	库存 Stock	Dc	镗孔范围(mm) Boring range	调节行程(mm) Adjustment	调节精度(mm) Adjustment accuracy	配合游标精度(mm) Vernier accuracy	配合主轴接口 Modular holder	重量 (kg)
21CD40-SMB	○	8	φ 3-32	-0.2 ~ 3	φ 0.01	φ 0.001	TMG21-40	0.98
21CD50-SMB	○	12	φ 3-40	-0.2 ~ 4	φ 0.01	φ 0.001	TMG21-50	1.26
21CD63-SMB	●	16	φ 3-50	-0.2 ~ 5	φ 0.01	φ 0.001	TMG21-63	1.45

● 常备库存  
Unallocated stock

◐ 可备库存  
Available stock

○ 订单生产  
Order production

## 使用配置图

Configuration diagram

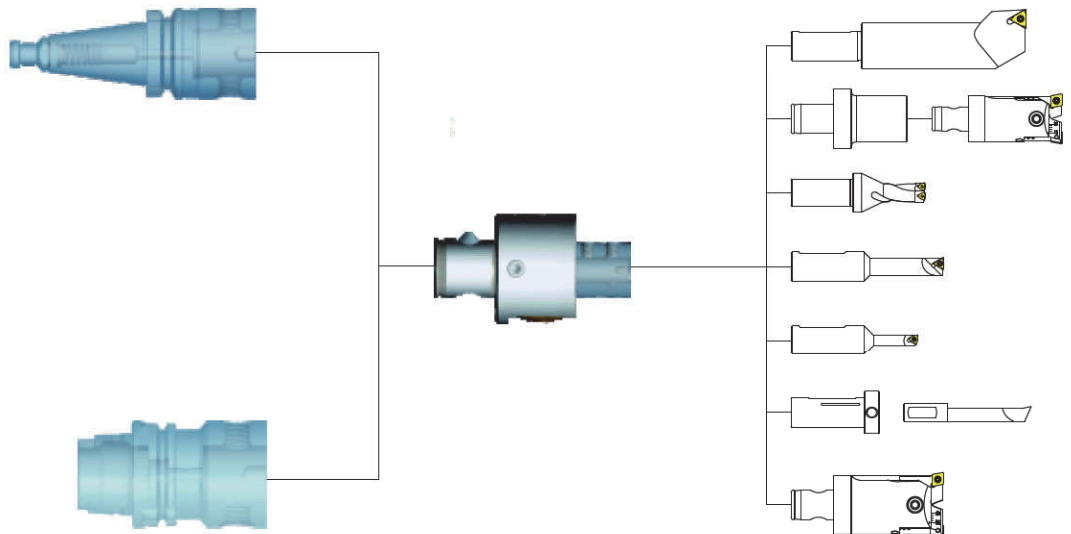

# C 孔加工刀具 Hole Making Tools

## SMB小孔径微调精镗刀

## SMB Small Micro-adjustable Fine Boring Tools

SBJ镗刀杆(适用于21CD63-SMB)

SBJ boring bar(Adapt to 21CD63-SMB)

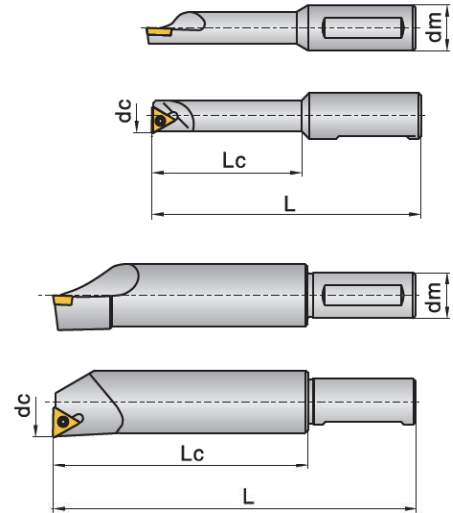

孔加工刀具

ROUGH BORING  
粗镗用刀具

FINISH BORING  
精镗用刀具

BORING UNIT  
镗削单元

型号 Type	库存 Stock	尺寸(mm) Dimension				刀片 Inserts	螺钉 Screw	扳手 Wrench	重量 (kg)
		dc	dm	Lc	L				
SBJ-1606-24	●	6~9	16	24	69	WB**060102	SIC020037	FT06	0.07
SBJ-1608-32	●	8~11	16	32	77	TB**060102	SIC020037	FT06	0.08
SBJ-1610-40	●	10~13	16	40	83	TB**060102	SIC020037	FT06	0.09
SBJ-1612-53	●	12~17	16	53	95	TP**090204L	SIC025065	FT07	0.10
SBJ-1616-68	●	16~21	16	68	108	TP**090204L	SIC025065	FT07	0.13
SBJ-1620-83	●	20~26	16	83	125	TP**110304L	SIC030072	FT09	0.21
SBJ-1625-90	●	25~31	16	90	128	TP**110304L	SIC030072	FT09	0.29
SBJ-1630-90	●	30~42	16	90	128	TP**110304L	SIC030072	FT09	0.30
SBJ-1640-90	●	40~50	16	90	128	TP**110304L	SIC030072	FT09	0.37

转接套(适用于21CD63-SMB)

Switching Sleeve(Adapt to 21CD63-SMB)

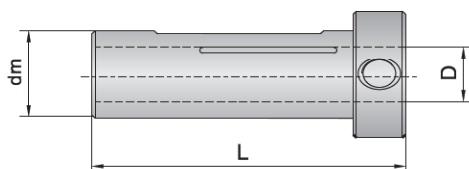

型号 Type	库存 Stock	尺寸(mm) Dimension			重量 (kg)
		dm	D	L	
SMB16-05	○	16	5	40	
SMB16-06	○	16	6	40	
SMB16-07	○	16	7	40	
SMB16-08	○	16	8	40	
SMB16-10	○	16	10	40	
SMB16-12	○	16	12	40	

● 常备库存  
Unallocated stock

◐ 可备库存  
Available stock

○ 订单生产  
Order production

# C 孔加工刀具 Hole Making Tools

## SMB小孔径微调精镗刀

## SMB Small Micro-adjustable Fine Boring Tools

### 加工示例

使用刀具	21CD63-SMB
使用镗杆	SBJ-1620-83
使用刀片	IPGH110304L IN60
加工材料	45#
材料硬度	300HB
加工深度	60mm
镗孔直径	20mm
机床接口	BT40
切削液	水溶液

切削速度 $V_c$	100 m/min
主轴转速 $n$	1600 r/min
进给速度 $F$	96 mm/min
每齿进给 $F_z$	0.06 mm/z
切削深度 $a_p$	0.1 mm



### 小孔精镗加工常见问题

#### 镗孔时刀具震动

检查刀具压紧位置  
降低转速  
添加动平衡调节环

#### 内孔表面质量不高

降低进给  
减小刀尖半径  
增大主轴转速

#### 内孔有锥度

检查底孔加工余量，若余量多则加大底孔，底孔余量小则减小底孔  
减小刀尖半径  
提高进给



# C 孔加工刀具 Hole Making Tools

## SMB小孔径微调精镗刀

## SMB Small Micro-adjustable Fine Boring Tools

### SBJ镗杆安装示意 Installation of SBJ boring bar

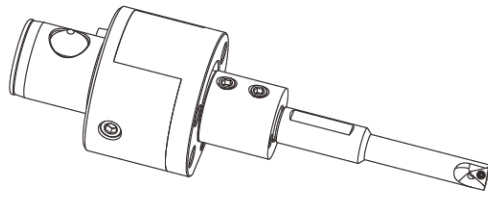

### 转接套使用示意 Using schematic for the switching sleeve

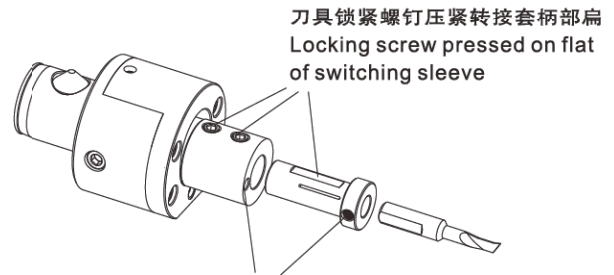

刀具锁紧螺钉压紧转接套柄部扁  
Locking screw pressed on flat  
of switching sleeve

转接套锁紧螺钉方向  
需要与刀具接口处的定位销方向一致  
Direction of switching sleeve locking screw need  
agree with direction of pinon cutter's interface

### SMB小孔径微调精镗刀调节指南

### Adjusting steps for SMB small micro-adjustable fine boring cutter

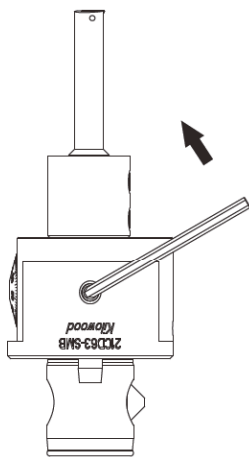

①

松开锁紧螺钉  
Loosen the locking screws

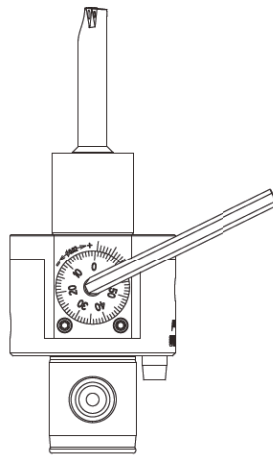

②

旋转刻度盘, 将刀具前端调至合适位置  
( $\phi 0.01\text{mm}$ )  
Turn the dial, adjust the graduation to  
the appropriate dimension  
( $\phi 0.01\text{mm}$ )

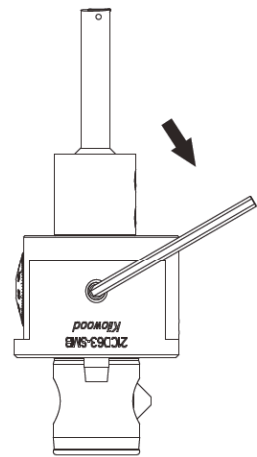

③

旋紧锁紧螺钉  
Tighten the locking screws

# C 孔加工刀具 Hole Making Tools

## SMB小孔径微调精镗刀

## SMB Small Micro-adjustable Fine Boring Tools

### 使用注意事项:

### Caution:

为保护微调机构，调整时不要用力过猛。

锁紧螺钉未松开前，请勿转动刻度盘，否则会损坏微调机构

当微调刻度盘旋转阻力很大或无法旋转时，请检查是否超出调节行程或锁紧螺钉是否松开。

镗孔时选择中心偏移最小的镗杆有利于使用高切削速度。

为保证使用效果，使用一段时间后，请通过注油杯向微调机构添加润滑油，建议使用轻质润滑油。

请注意防锈，不用时请涂抹防锈油防锈，严禁将小孔径微调精镗刀完全浸入防锈油中。

镗孔后退刀时注意退刀方向和退刀距离，否则会损坏机床和刀具

刀具上的锁紧螺钉必需压紧在镗杆的压紧平面上，否则会破坏配合面使镗杆取出困难。

Slowly adjust, avoid excessive adjust.

Do not turn dial before loosen locking screw for adjustment

When it's hard to turn dial, please check max. adjustment or lock screw for adjustment

Selecting boring bar of the minimum center offset is helpful to use high cutting speed

In order to ensure the accuracy, please add lubricating oil every once in a while, through oil cup, light oil recommended.

pay attention to rust, please daub anti-rust oil, it was prohibited that cutting tools completely immersed in anti-rust oil

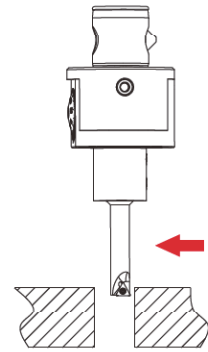

退刀方向

### 特别注意

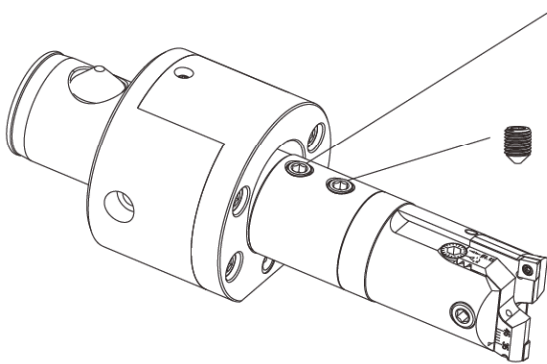

精镗刀配双刃镗刀时，此处螺钉不装配

SMB micro-adjustable boring tool with

HBA rough boring cutter, this screw need not assemble

此螺钉更换为锥端螺钉：21A.32-E1

This screws should be replaced by screw: 21A.32-E1

# C 孔加工刀具 Hole Making Tools

HBM 微调精镗刀

HBM Micro-adjustable Fine Boring Tools

镗孔范围：φ 20~ φ 200mm

配合游标最小调节精度0.002mm/div

TMG21高刚性接口、螺纹接口、直柄接口

## 镗头可换

只需要更换镗刀头，即可增大加工范围，同时可根据加工需求组合镗刀头与刀体，增大镗刀刀体与孔壁间的空隙，改善排屑性能。



## 反镗加工

在加工工件背面的孔时，一般需要将工件反装，这不仅很难保证前后加工孔的同轴度，而且增加装夹次数，降低加工效率，HBM微调精镗刀只需要将镗刀头反装即可进行反镗加工，节约装夹时间，降低生产成本。

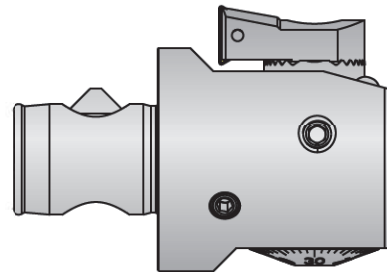

反镗时主轴需反转

## 加工方式多样

使用方式多样，可镗通孔、盲孔等

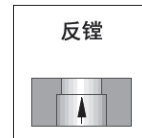
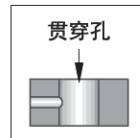
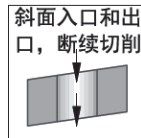
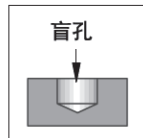
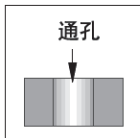

## 调节方法

1. 松开锁紧螺钉1，预保持一定的预紧力
2. 旋转微调螺钉2，设定目标直径
3. 拧紧锁紧螺钉1



注意：  
切勿在未松开锁紧螺钉情况下旋转微调螺钉，否则微调机构容易损坏

## 反镗底孔计算

反镗加工计算

底孔直径 D1  
刀体最大外形 D2  
加工直径 D

$$D1 > \frac{D2 + D}{2} + 0,5$$

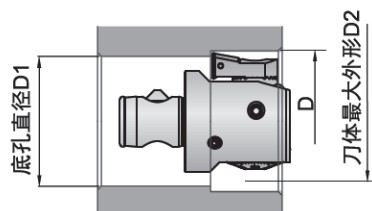

# C 孔加工刀具 Hole Making Tools

HBM 微调精镗刀

HBM Micro-adjustable Fine Boring Tools

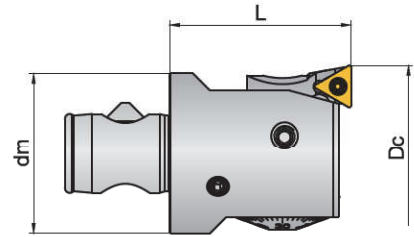

正镗

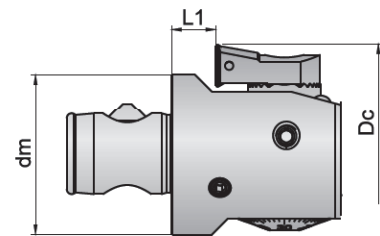

反镗

刀片 Inserts	螺钉 Screw	扳手 Wrench
TB..060102	SIC020050A	FT06
TC..090204	SIC022063	FT07
TC..110204	SIC025065	FT07



型号 Type	尺寸(mm) Demension					镗刀头 Fine boring head	刀片 Inserts	重量 (kg)
	Dc		dm	L1	L			
	正镗范围	反镗范围						
21CD25-HBM27-35	27~35	-	25	-	35	HBM27-27	TB..060102	0.13
	34~42	35~42		11				
21CD32-HBM35-40	35~44	40~44	32	14	40	HBM35-35	TC..090204	0.23
	43~52	43~52				HBM35-43		
21CD40-HBM44-45	44~55	48~55	40	11	45	HBM44-44	TC..110204	0.43
	54~65	54~65				HBM44-54		
21CD50-HBM55-50	55~71	65~71	50	12	50	HBM55-55	TC..110204	0.80
	68~84	68~84				HBM55-68		
21CD63-HBM69-60	69~99	80~99	63	12	60	HBM69-69	TC..110204	1.53
	91~121	91~121				HBM69-68		
21CD63-HBM90-70	90~140	101~140	80	12	70	HBM90-90	TC..110204	2.74
	120~170	120~170				HBM90-120		
21CD80-HBM90-70	90~140	101~140	80	12	70	HBM90-90	TC..110204	2.74
	120~170	120~170				HBM90-120		
21CD100-HBM120-80	120~170	131~170	100	12	80	HBM120-120	TC..110204	4.53
	150~200	150~200				HBM120-170		

# C 孔加工刀具 Hole Making Tools

HBM 微调精镗刀

HBM Micro-adjustable Fine Boring Tools

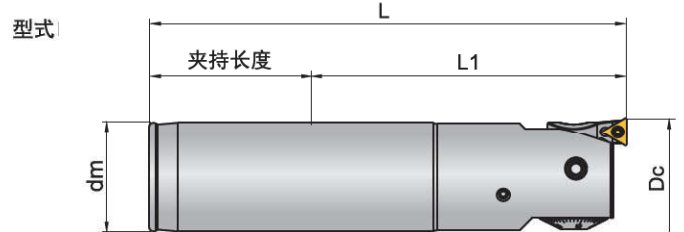

型式 II (不能用于反镗)

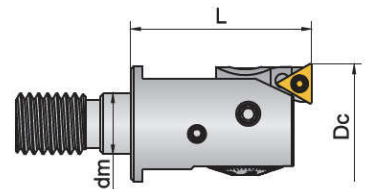

孔加工刀具

ROUGH BORING  
粗镗用刀具

FINISH BORING  
精镗用刀具

BORING UNIT  
镗削单元

刀片 Inserts	螺钉 Screw	扳手 Wrench
TB..060102	SIC020050A	FT06
TC..090204	SIC022063	FT07
TC..110204	SIC025065	FT07

型号 Type	尺寸(mm) Demension					镗刀头 Fine boring head	刀片 Inserts	型式 Model	重量 (kg)
	Dc		dm	L1	L				
	正镗范围	反镗范围							
A20-HBM20-100	20~25	-	19	100	150	HBM20-20	TB..060102	I	0.29
	24~29	-				HBM20-24			
A25-HBM27-125	27~35	-	25	125	181	HBM27-27	TB..060102	I	0.60
	34~42	35~42				HBM27-34			
A32-HBM35-160	35~44	40~44	32	160	220	HBM35-35	TC..090204	I	1.23
	43~52	43~52				HBM35-43			
A40-HBM44-200	44~55	48~55	40	200	270	HBM44-44	TC..110204	I	2.46
	54~65	54~65				HBM44-54			
DM10-HBM20-30	20~25	-	10.5	-	30	HBM20-20	TB..060102	II	0.06
	24~29	-				HBM20-24			
DM12-HBM27-35	27~35	-	12.5	-	35	HBM27-27	TB..060102	II	0.13
	34~42	-				HBM27-34			
DM16-HBM35-40	35~44	-	17	-	40	HBM35-35	TC..090204	II	0.18
	43~52	-				HBM35-43			
DM16-HBM44-45	44~55	-	17	-	45	HBM44-44	TC..110204	II	0.40
	54~65	-				HBM44-54			



# C 孔加工刀具 Hole Making Tools

HBM 微调精镗刀

HBM Micro-adjustable Fine Boring Tools

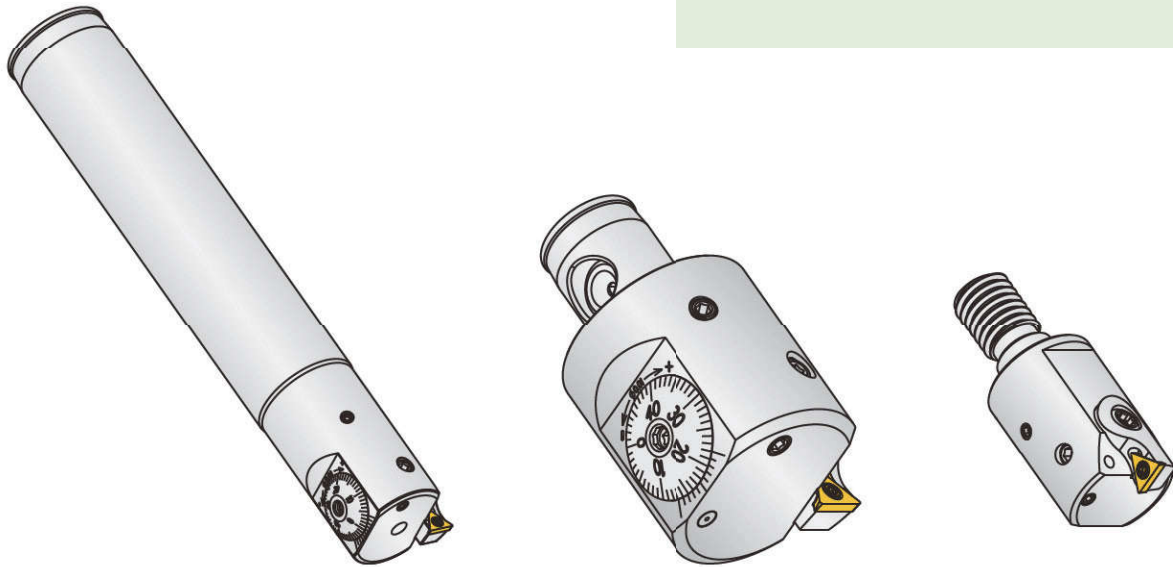

型号 Type	微调单元 Micro-adjustable unit	喷嘴 Nozzle	镗头压紧螺钉 Screw for boring head	锁紧螺钉 Screw for lock	扳手 Wrench
...-HBM20-...	HBM20	NOZZLE4	SIC035080	SSC040050	S2
...-HBM27-...	HBM27	NOZZLE4	SIC040084A	SSC050060	S2.5
...-HBM27-...	HBM27	NOZZLE4	SIC040084A	SSC050060	S2.5
...-HBM35-...	HBM35	NOZZLE6	SIC050080A	SSC050080	S2.5
...-HBM44-...	HBM44	NOZZLE6	SIC060120A SIC060160A	SSC060100	S3
...-HBM55-...	HBM55	NOZZLE8	SCC060120	SSC080100	S4
...-HBM69-...	HBM69	NOZZLE8	SCC080120	SSC100120	S5
...-HBM90-...	HBM90	NOZZLE10	SCC080120	SSC100120	S5
...-HBM120-...	HBM120	NOZZLE10	SCC080120	SSC100120	S5

孔加工刀具

粗镗用刀具  
ROUGH BORING

精镗用刀具  
FINISH BORING

镗削单元  
BORING UNIT

# C 孔加工刀具 Hole Making Tools

## MBQ 微调精镗刀

## MBQ Micro-adjustable Fine Boring Tools

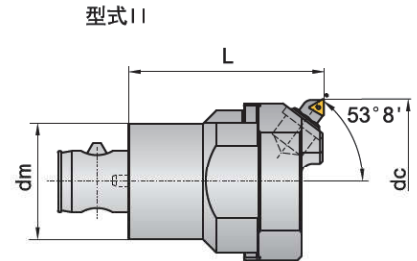
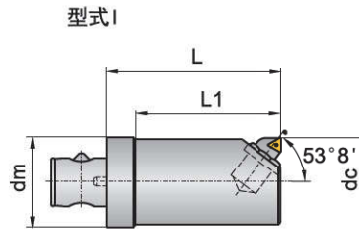

调节精度:  $\phi 0.02\text{mm/格}$



孔加工刀具

ROUGH BORING  
粗镗用刀具

FINISH BORING  
精镗用刀具

BORING UNIT  
镗削单元

型号 Type	库存 Stock	尺寸(mm) Dimension				刀片 Inserts	镗刀头 Fine boring head	型式 Model	重量 (kg)
		dc	dm	L1	L				
21CD25-MBQ0260-50	●	26~30	25	41	50	CC..060204	MB-31-CC06L	I	0.16
21CD25-MBQ0290-50	●	29~33	25	-	50	CC..060204	MB-31-CC06L	I	0.18
21CD32-MBQ0320-60	●	32~36	32	50	60	CC..060204	MB-31-CC06L	I	0.33
21CD32-MBQ0350-60	●	35~40.6	32	-	60	TC..090204	MB-32-TC09L	I	0.34
21CD40-MBQ0396-60	●	39.6~45.2	40	48	60	TC..090204	MB-32-TC09L	I	0.48
21CD40-MBQ0442-60	●	44.2~49.8	40	-	60	TC..090204	MB-32-TC09L	I	0.56
21CD40-MBQ0488-60	●	48.8~58.4	40	-	60	TC..110204	MB-33-TC11L	I	0.58
21CD50-MBQ0574-70	●	57.4~67	50	-	70	TC..110204	MB-33-TC11L	I	1.15
21CD63-MBQ0660-70	●	66~75.6	63	-	70	TC..110204	MB-33-TC11L	I	1.74
21CD63-MBQ0750-70	●	75~84.6	63	-	70	TC..110204	MB-33-TC11L	I	2.02
21CD63-MBQ0840-70	●	84~93.6	63	-	70	TC..110204	MB-33-TC11L	I	2.87
21CD80-MBQ0840-70	●	84~93.6	80	-	70	TC..110204	MB-33-TC11L	I	3.06
21CD63-MBQ0900-85	●	90~150	63	-	85	TC..090204	MB-32-TC09L	II	2.37
21CD80-MBQ1240-95	●	124~180	80	-	95	TC..090204	MB-32-TC09L	II	4.52
21CD80-MBQ1750-95	●	175~210	80	-	95	TC..090204	MB-32-TC09L	II	5.14

型号 Type	滑销 Slide pin	定位销 Location pin	冷却管 Coolant hose
21CD25-*****	21A25-E3	21A25-E4	21A25-E6
21CD32-*****	21A32-E3	21A32-E4	21A32-E6
21CD40-*****	21A40-E3	21A40-E4	21A40-E6
21CD50-*****	21A50-E3	21A50-E4	21A50-E6
21CD63-*****	21A63-E3	21A63-E4	21A63-E6
21CD80-*****	21A80-E3	21A80-E4	21A80-E6

刀片 Inserts	螺钉 Screw	扳手 Wrench
CC..060204	SIC025065	FT07
TC..090204	SIC022063	FT07
TC..110204	SIC025065	FT07

● 常备库存 Unallocated stock    ● 可备库存 Available stock    ○ 订单生产 Order production

# 孔加工刀具 Hole Making Tools

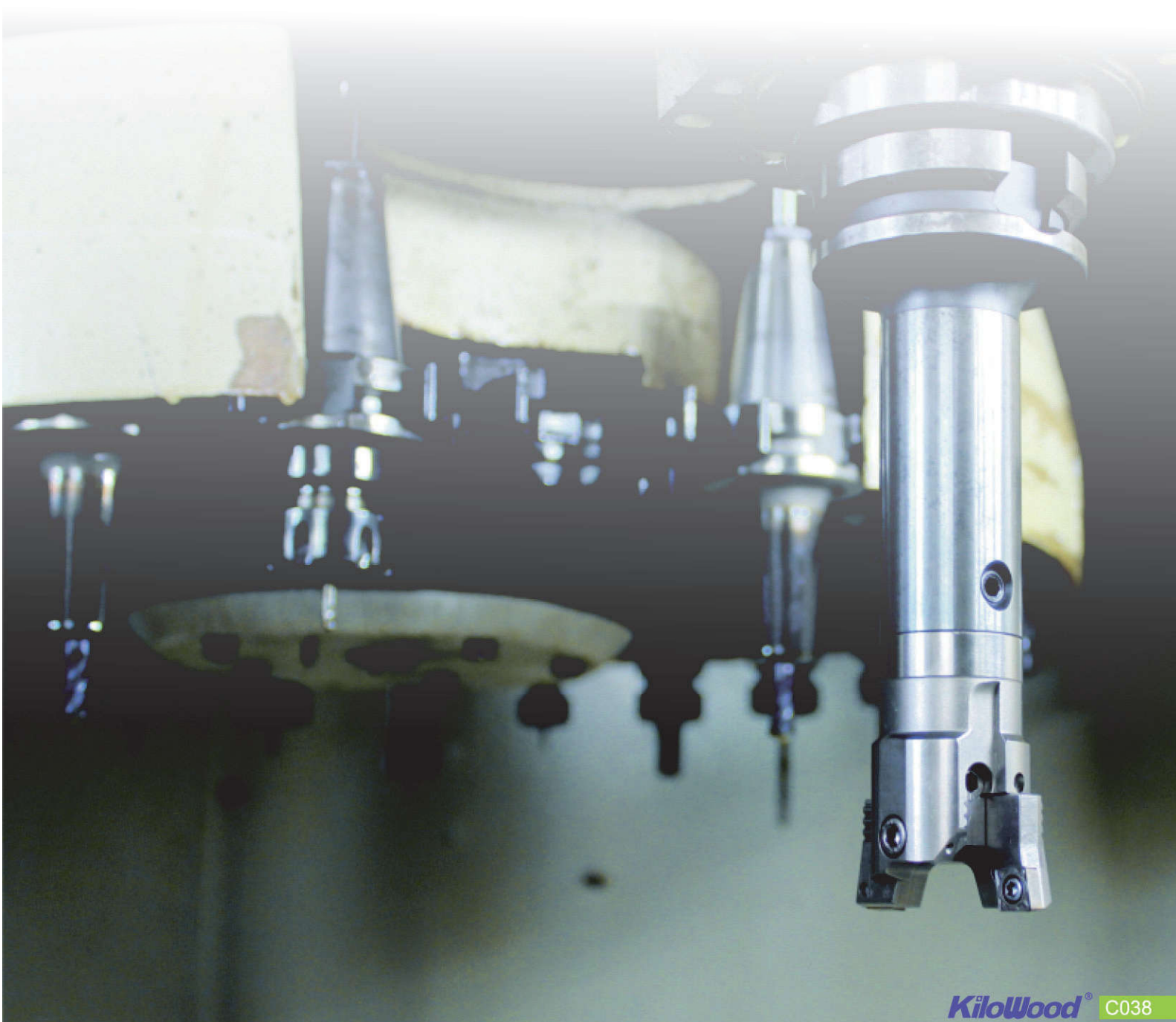
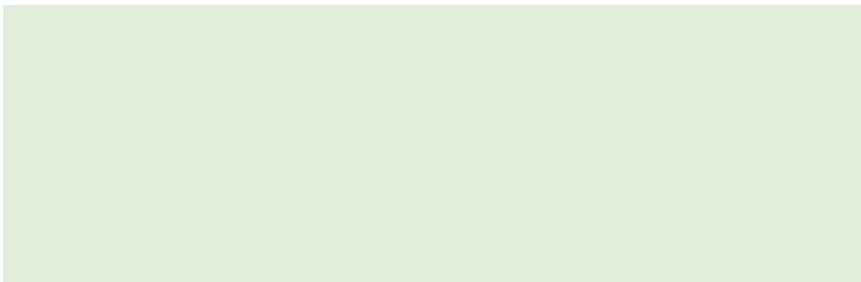

# C 孔加工刀具 Hole Making Tools

HBH大直径精镗刀

HBH Large Diameter Fine Boring Tools



型式 I

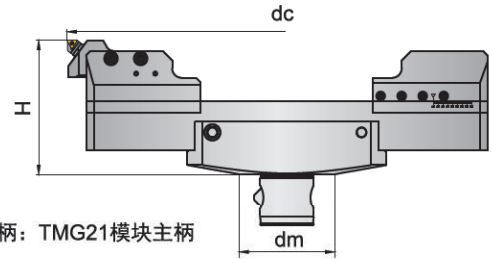

适用刀柄: TMG21模块手柄



型式 II

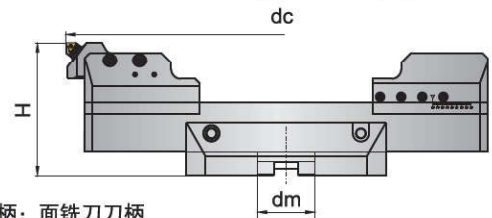

适用刀柄: 面铣刀刀柄



刀片 Inserts	螺钉 Screw	扳手 Wrench
TC..090204	SIC022063	FT07
TC..110204	SIC025065	FT07

型号 Type	库存 Stock	尺寸(mm) Dimension			刀片 Inserts	MB精镗刀头 Fine boring head	型式 Model	重量 (kg)
		dc	dm	H				
21CD63-HBH150M	●	φ 150~φ 215	63	90	TC..090204	MB-32-TC09L	I	3.74
S32-HBH150M	●	φ 150~φ 215	32	115	TC..090204	MB-32-TC09L	II	4.48
21CD63-HBH215M	●	φ 215~φ 280	63	90	TC..090204	MB-32-TC09L	I	4.33
S32-HBH215M	●	φ 215~φ 280	32	115	TC..090204	MB-32-TC09L	II	5.07
21CD80-HBH280M	●	φ 280~φ 370	80	95	TC..090204	MB-32-TC09L	I	7.61
T40-HBH280M	●	φ 280~φ 370	40	95	TC..090204	MB-32-TC09L	II	7.52
21CD80-HBH370M	●	φ 370~φ 460	80	95	TC..090204	MB-32-TC09L	I	8.47
T40-HBH370M	●	φ 370~φ 460	40	95	TC..090204	MB-32-TC09L	II	8.38
21CD100-HBH460ALM	●	φ 460~φ 580	100	155	TC..110204	MB-33-TC11L	I	17.61
T60-HBH460ALM	●	φ 460~φ 580	60	155	TC..110204	MB-33-TC11L	II	17.20
21CD100-HBH580ALM	●	φ 580~φ 700	100	160	TC..110204	MB-33-TC11L	I	19.84
T60-HBH580ALM	●	φ 580~φ 700	60	160	TC..110204	MB-33-TC11L	II	19.43
21CD100-HBH700ALM	●	φ 700~φ 820	100	165	TC..110204	MB-33-TC11L	I	22.29
T60-HBH700ALM	●	φ 700~φ 820	60	165	TC..110204	MB-33-TC11L	II	21.88
21CD100-HBH820ALM	●	φ 820~φ 940	100	170	TC..110204	MB-33-TC11L	I	25.79
T60-HBH820ALM	●	φ 820~φ 940	60	170	TC..110204	MB-33-TC11L	II	25.38
21CD100-HBH940ALM	●	φ 940~φ 1060	100	175	TC..110204	MB-33-TC11L	I	27.84
T60-HBH940ALM	●	φ 940~φ 1060	60	175	TC..110204	MB-33-TC11L	II	27.43

● 常备库存  
Unallocated stock

● 可备库存  
Available stock

○ 订单生产  
Order production



# C 孔加工刀具 Hole Making Tools

## 面铣刀接柄大直径镗刀安装说明

Direction for installation of large diameter boring tools with face mill connector

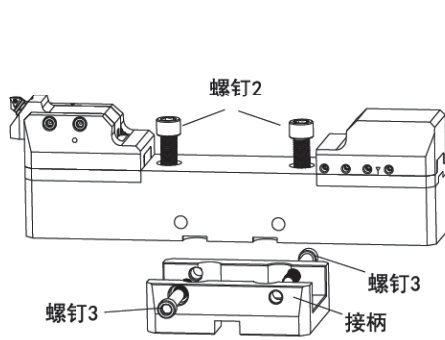

1. 松开螺钉2和螺钉3，卸下接柄。

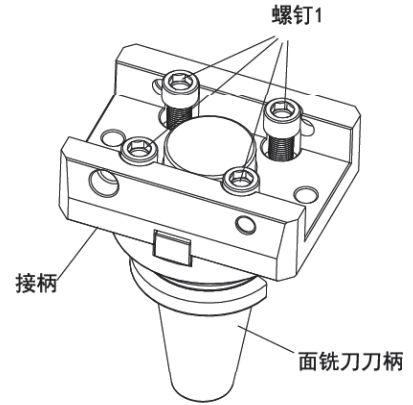

2. 清理要贴合的面，将接柄装入面铣刀刀柄，锁紧螺钉1

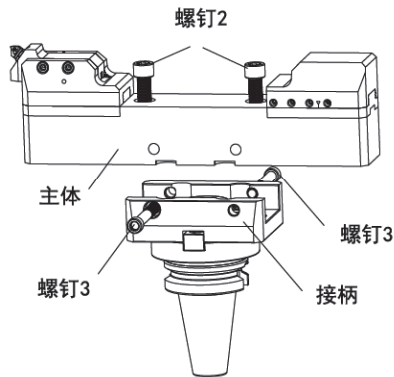

3. 清理要贴合的面，将主体装入接柄中，锁紧螺钉2和螺钉3。

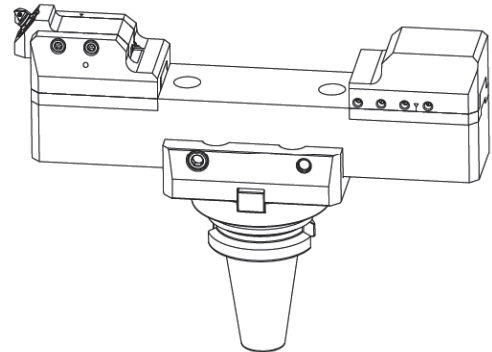

4. 完成安装。

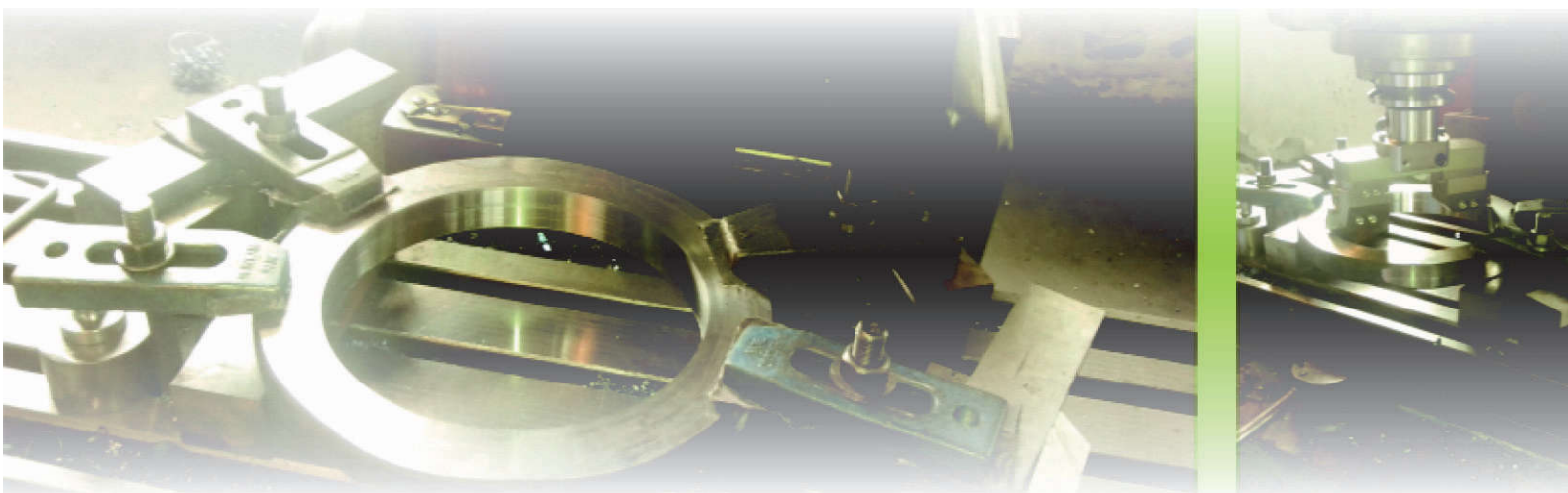

# C 孔加工刀具 Hole Making Tools

HBH大直径精镗刀

HBH Large Diameter Fine Boring Tools

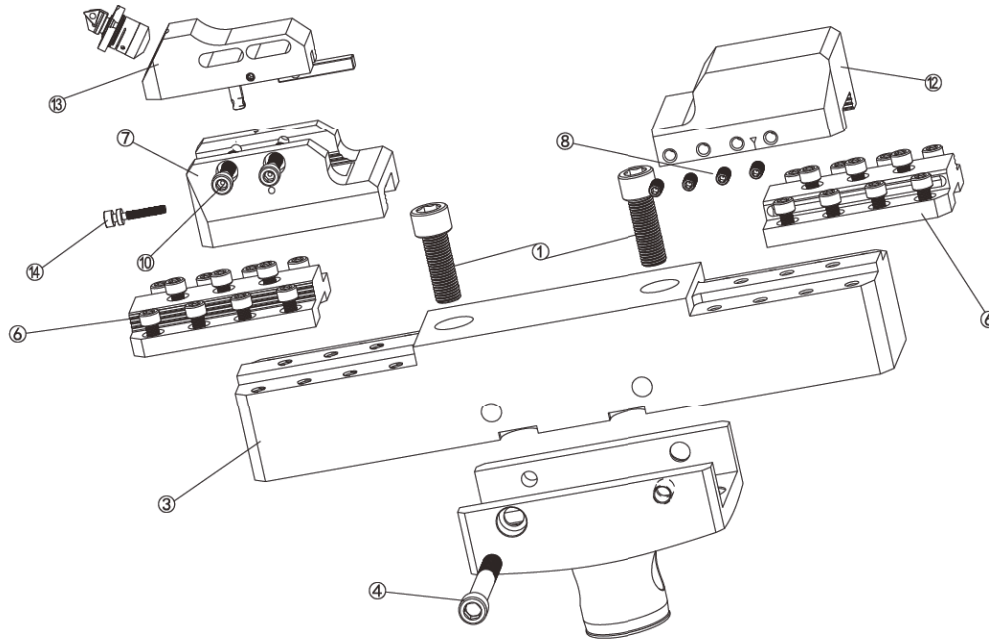

孔加工刀具

ROUGH BORING  
粗镗用刀具

FINISH BORING  
精镗用刀具

BORING UNIT  
镗削单元

接柄 Connection holder	①螺钉 Screw	②扳手 Wrench	③主体 Body	④螺钉 Screw	⑤扳手 Wrench	⑥连接块 Connection block	⑦刀座 Supporting chasis
21CD63-HBH	SCC080300	-	HBH150	SCC080600	-	-	HBH-65Z
S32-HBH				SCC080700			
21CD63-HBH	SCC080300	-	HBH215	SCC080600	-	-	HBH-65Z
S32-HBH				SCC080700			
21CD80-HBH	SCC120350	S10	HBH280	SCC100750	S8	-	HBH-90Z
T40-HBH				SCC100850			
21CD80-HBH	SCC120350	S10	HBH370	SCC100750	S8	-	HBH-90Z
T40-HBH				SCC100850			
21CD100-HBH	SCC160450	S14	HBH460AL	SCC120950	S10	HBH-120S	HBH-120Z
T60-HBH			SCC1201100				
21CD100-HBH			HBH580AL	SCC120950			
T60-HBH			SCC1201100				
21CD100-HBH			HBH700AL	SCC120950			
T60-HBH			SCC1201100				
21CD100-HBH			HBH820AL	SCC120950			
T60-HBH			SCC1201100				
21CD100-HBH			HBH940AL	SCC120950			
T60-HBH			SCC1201100				









# C 孔加工刀具 Hole Making Tools

HBH大直径精镗刀

HBH Large Diameter Fine Boring Tools



接柄 Connection holder	⑧螺钉 Screw 	⑨扳手 Wrench 	⑩螺钉 Screw 	⑪扳手 Wrench 	⑫配重块 Balance block 	⑬精镗刀头 Fine boring head 	⑭微调螺钉 Adjusting screw 
21CD63-HBH S32-HBH	SZC080160	S4	SCC080350	S6	HBH-65W	HBH-65M	HBMS-2-28
21CD80-HBH T40-HBH			SCC080400		HBH-90W	HBH-90M	
21CD100-HBH T60-HBH			SCC080500		HBH-120W	HBH-120M	
21CD100-HBH T60-HBH							
21CD100-HBH T60-HBH							
21CD100-HBH T60-HBH							
21CD100-HBH T60-HBH							
21CD100-HBH T60-HBH							
21CD100-HBH T60-HBH							
21CD100-HBH T60-HBH							
21CD100-HBH T60-HBH							
21CD100-HBH T60-HBH							
21CD100-HBH T60-HBH							
21CD100-HBH T60-HBH							

孔加工刀具  
粗镗用刀具  
ROUGH BORING  
精镗用刀具  
FINISH BORING  
镗削单元  
BORING UNIT

# C 孔加工刀具 Hole Making Tools

孔加工刀具

ROUGH BORING  
粗鏜用刀具

FINISH BORING  
精鏜用刀具

BORING UNIT  
镗削单元



# C 孔加工刀具 Hole Making Tools

## MB 微调精镗单元 MB Micro-adjustable Fine Boring Unit

### 创新涂层 Innovative Coating

针对微调精镗单元专门开发的创新涂层，更好的耐磨性与润滑性显著增加微调精镗单元使用寿命  
Coating designed specially for micro-adjustable fine boring unit, better anti-wear and lubricity properties prolong service life of boring unit.



### 多变刀头 Changeable Cutter Head

可根据客户刀片定制微调精镗单元  
可提供多种主偏角微调精镗单元  
螺杆可单独订购，并提供更换服务  
Fine boring unit can be customized for customer's inserts  
variety of cutting edge angle can be provided  
changeable Screw can be ordered separately with installation service.

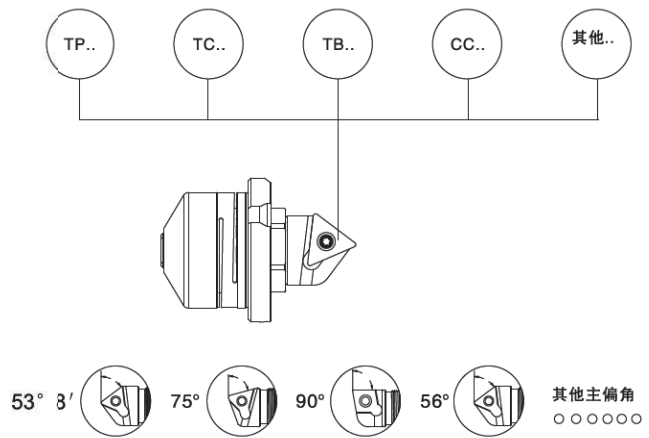

### 高效调节 Efficient Adjustment

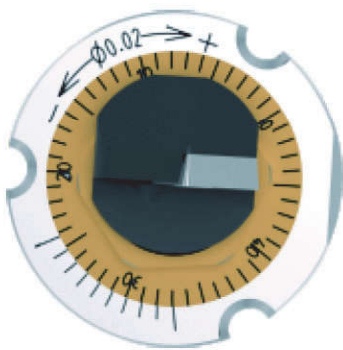

角度安装 Angular Mounting

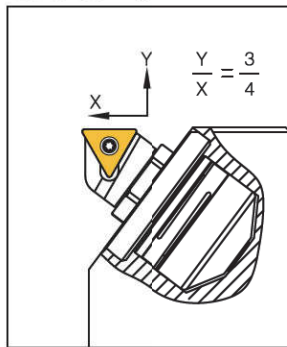

直角安装 Right Angle Mounting

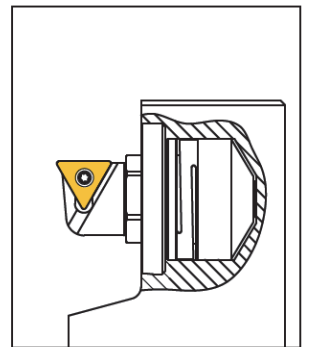

完美自锁  
调节前无需解锁  
调节后无需锁定  
Perfect self-lock system  
No need for lock and unlock during adjustment

调节精度 $\phi$ 0.02mm/格  
配合游标可达到 $\phi$ 0.002 mm 每游标格  
Adjustment precision is 0.02mm/grid  
Can be achieved at 0.002 mm / grid with the vernier

角度安装方式调节尺寸换算简便  
Size conversion easily for angular mounting  
明确的调节方向标识减少错误调节  
Clearly adjustment sign avoids errors

前端调节  
Front-end adjustment

# C 孔加工刀具 Hole Making Tools

## MB 微调精镗单元

## MB Micro-adjustable Fine Boring Unit

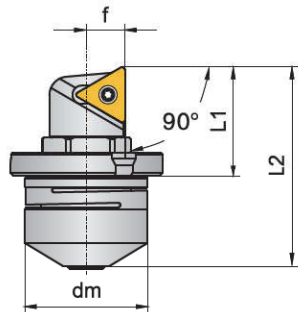

Fig.1

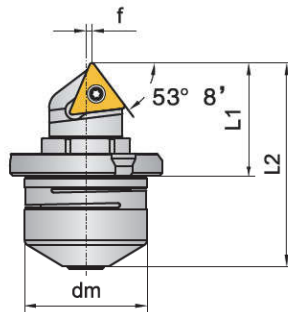
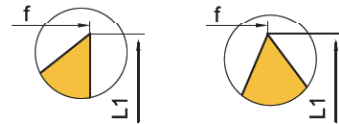

Fig.2



刀尖圆弧r=0  
Tip diameter r=0

图示精镗单元为左刀 Picture shows left hand version

型号 Type		库存 Stock		Fig.	尺寸(mm) Dimension					刀片 Inserts	重量 (kg)
左刀 Left hand	右刀 Right hand	左 Left	右 Right		dm	L1	L2	f	Dmin		
MB-11-CC06L	MB-11-CC06R	●	●	1	16	13.3	24.1	5.1	27	CC..060204	0.02
MB-11-TB06L	MB-11-TB06R	●	●		16	13.3	24.1	5.1	27	TB..060102	0.02
MB-12-TC09L	MB-12-TC09R	●	●		20	18.3	32.9	6.3	36.5	TC..090204	0.05
MB-12-TP09L	MB-12-TP09R	●	●		20	18.3	32.9	6.3	36.5	TP..090204	0.05
MB-13-TC11L	MB-13-TC11R	●	●		22	22.1	44.3	7.2	48.5	TC..110204	0.10
MB-13-TP11L	MB-13-TP11R	●	●		22	22.1	44.3	7.2	48.5	TP..110304	0.10
MB-14-TC16L	MB-14-TC16R	●	●		32	32	62.7	10.3	68.4	TC..16T308	0.29
MB-14-TP11L	MB-14-TP11R	●	●		32	32	62.7	10.3	68.4	TP..110304	0.29
MB-31-CC06L	MB-31-CC06R	●	●	2	16	14.3	25.15	0.45	25.2	CC..060204	0.02
MB-31-TB06L	MB-31-TB06R	●	●		16	14.3	25	0.2	24.8	TB..060102	0.02
MB-32-TC09L	MB-32-TC09R	●	●		20	19.1	33.7	0.9	32.5	TC..090204	0.05
MB-32-TP09L	MB-32-TP09R	●	●		20	19.1	33.7	0.9	32.5	TP..090204	0.05
MB-33-TC11L	MB-33-TC11R	●	●		22	23	45.3	1.1	42	TC..110204	0.10
MB-33-TP11L	MB-33-TP11R	●	●		22	23	45.3	1.1	42	TP..110304	0.10
MB-34-TC16L	MB-34-TC16R	●	●		32	33.3	62.3	1.2	59.4	TC..16T308	0.29
MB-34-TP11L	MB-34-TP11R	●	●		32	33.3	62.3	1.2	59.4	TP..110304	0.29

编号规则  
Rule for Designation

● 常备库存  
Unallocated stock

◐ 可备库存  
Available stock

○ 订单生产  
Order production

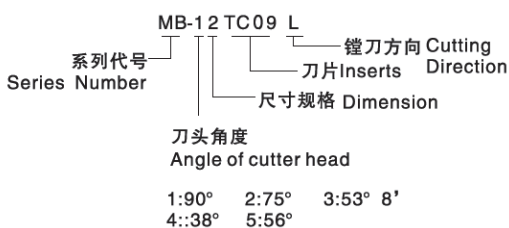



# C 孔加工刀具 Hole Making Tools

MB 微调精镗单元

MB Micro-adjustable Fine Boring Unit



备件 Spare parts

刀片 Inserts	螺钉 Screw 	扳手 Wrench 
CC..060204	SIC025065	FT07
TB..060102	SIC020037	FT06
TC..090204	SIC022063	FT07
TP..090204	SIC025065	FT07
TC..110204	SIC025065	FT07
TP..110304	SIC030072	FT09
TC..16T308	SIC035080	FT15

备件 Spare parts

型号 Type	定位螺钉 Location screw 	螺钉扳手 Screw wrench 	微调扳手 Adjusting wrench 
MB-*1-****	SIC030072	FT09	MB-1-3
MB-*2-****	SIC030072	FT09	MB-2-3
MB-*3-****	SIC040084	FT15	MB-3-3
MB-*4-****	SKC050120	S3	MB-4-3

# C 孔加工刀具 Hole Making Tools

## MB 微调精镗单元

## MB Micro-adjustable Fine Boring Unit

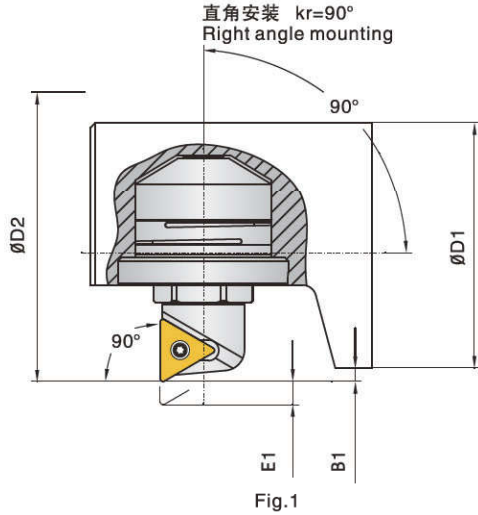

Fig.1

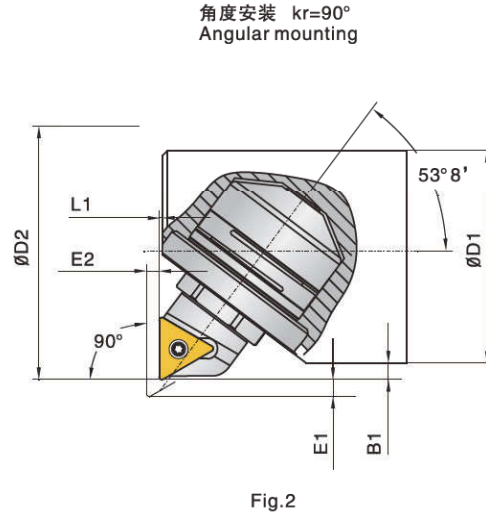

Fig.2

型号 Type		Fig.	刀尖圆弧 Tip diameter	尺寸(mm) Dimension					
左刀 Left hand	右刀 Right hand			D1min	D2min	B1min	E1max	E2max	L1
MB-11-CC06L	MB-11-CC06R	1	0.4	26	27.6	0.55	2.5	-	-
MB-11-TB06L	MB-11-TB06R		0.2	26	27.9	0.6	2.5	-	-
MB-12-TC09L	MB-12-TC09R		0.4	34.5	37.1	1.3	3.5	-	-
MB-12-TP09L	MB-12-TP09R		0.4	34.5	37.1	1.3	3.5	-	-
MB-13-TC11L	MB-13-TC11R		0.4	46.5	49.1	1.3	6	-	-
MB-13-TP11L	MB-13-TP11R		0.4	46.5	49.1	1.3	6	-	-
MB-14-TC16L	MB-14-TC16R		0.8	67	69	1	10	-	-
MB-14-TP11L	MB-14-TP11R		0.4	67	69.6	1.3	10	-	-
MB-31-CC06L	MB-31-CC06R	2	0.4	22	25.9	1.65	2	1.5	0.5
MB-31-TB06L	MB-31-TB06R		0.2	22	25.7	1.5	2	1.5	0.5
MB-32-TP09L	MB-32-TP09R		0.4	28.5	33.1	2.3	2.8	2.1	0.5
MB-32-TC09L	MB-32-TC09R		0.4	28.5	33.1	2.3	2.8	2.1	0.5
MB-33-TC11L	MB-33-TC11R		0.4	38	42.6	2.3	4.8	3.6	0.5
MB-33-TP11L	MB-33-TP11R		0.4	38	42.6	2.3	4.8	3.6	0.5
MB-34-TC16L	MB-34-TC16R		0.8	55	60	2.5	8	6	0.5
MB-34-TP11L	MB-34-TP11R		0.4	55	60.6	2.8	8	6	0.5

常备库存 Unallocated stock    
  可备库存 Available stock    
  订单生产 Order production



# C 孔加工刀具 Hole Making Tools

## MB 微调精镗单元

## MB Micro-adjustable Fine Boring Unit

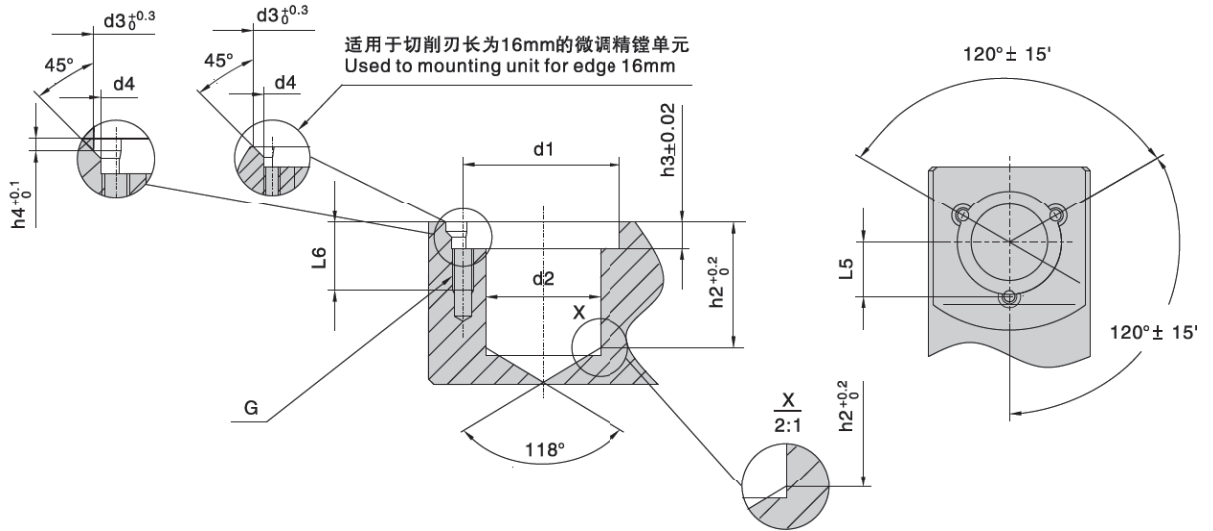

型号 Type	尺寸(mm) Dimension									
	h2	h3	h4	d1	d2	d3	d4	G	L6	L5
MB-*1-****	11.5	2.8	1.6	19	16	4.6	3.2	M3	9	9.65±0.02
MB-*2-****	15.5	4	1.6	25	20	4.6	3.2	M3	9	12.5±0.02
MB-*3-****	24	5	1.8	30	22	6.5	4.3	M4	13	15.4±0.02
MB-*4-****	33	6.3	-	46	32	11.9	5.4	M5	16	23.0±0.02

### 使用注意事项

### Caution

- 初次安装精镗单元时，请将定位孔清理干净，并按规定主偏角安装。
- 在恶劣切削条件（粉尘、铁屑等）调节镗孔直径时，必须清理螺孔，以防止异物进入螺孔中。
- 请不要将刀杆拧松到超出扳手所标识的调节范围。若超出调节范围，将造成微调精镗单元损坏。
- 为保证使用寿命，请使用原厂配件。

#### Caution:

- Clean the locating hole and install cutting edge angle accordingly for first installation.
- When adjusting the bore diameter in severe cutting condition (dust, chips, etc.), please avoid any contamination into the screw hole
- Do not loosen the boring bar out of adjustment range signed by wrench, unrecovered damage may occur.
- In order to get guarantee service life and accuracy, use original spare part

MB微调精镗单元已经使用于本公司的  
MBQ系列微调精镗刀（精镗直径26-210）  
HBH系列大直径精镗刀（精镗直径150-1060）

MB micro-adjustable fine boring unit has been installed in  
MBQ micro adjustable boring tools ( boring diameter 26-210mm )  
HBH large diameter fine boring tools ( boring diameter 150-1060mm )

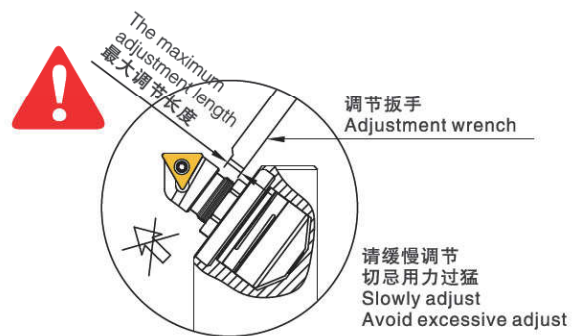

# C 孔加工刀具 Hole Making Tools

## MB 微调精镗单元

## MB Micro-adjustable Fine Boring Unit

MB系列微调精镗单元在非标刀具中的应用

Application of MB Micro-Adjustable Fine Boring Unit in customized tools

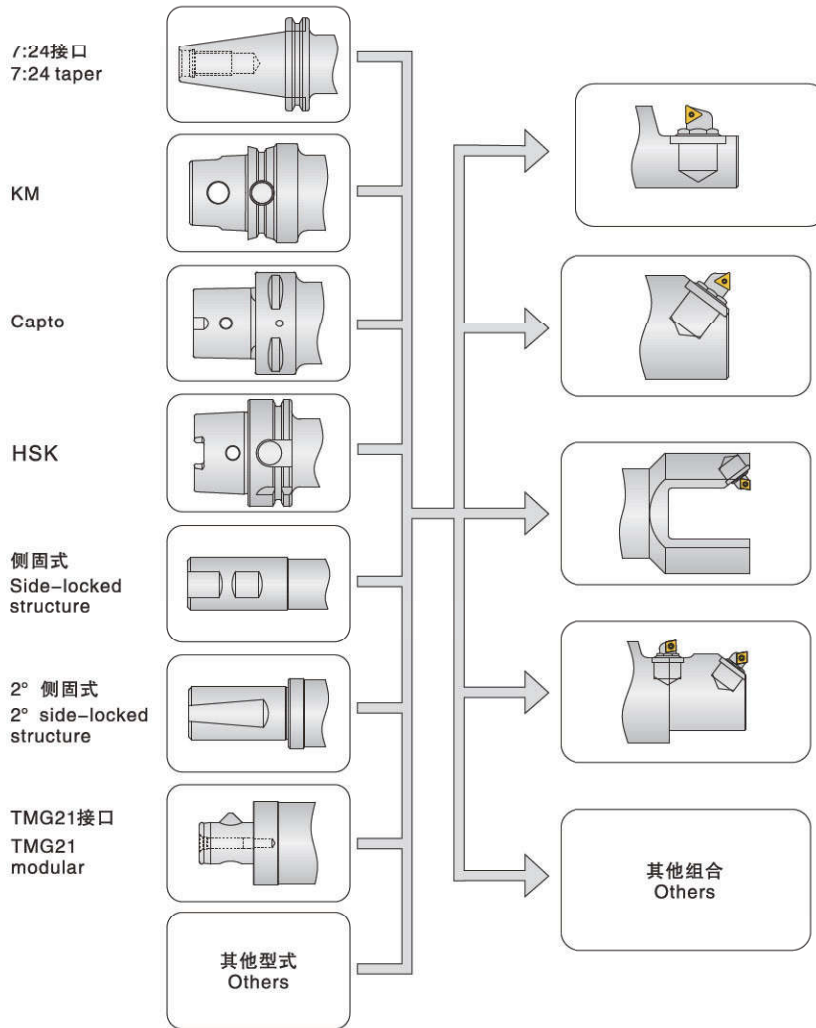

示例: Example

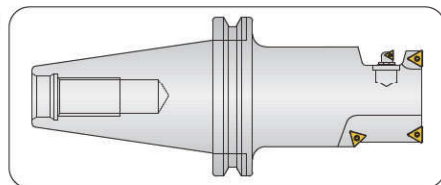

# C 孔加工刀具 Hole Making Tools

## MAC微调小刀夹 MAC Micro-adjustable Cartridge

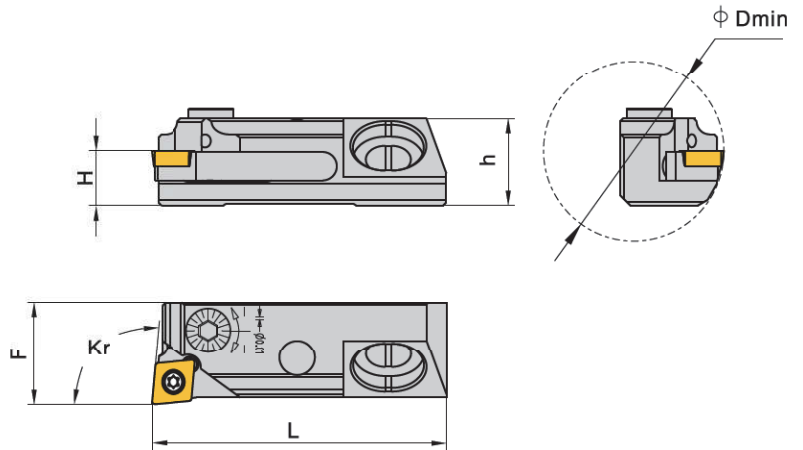

图示为右刀  
Picture shows right hand version

型号 Type		库存 Stock		尺寸(mm) Dimension						刀片 Inserts
左刀 Left hand	右刀 Right hand	左 Left	右 Right	Kr	F	H	h	L	Dmin	
MAC-L16-CC06L	MAC-L16-CC06R	●	●	95	16	8.5	13.5	46	28	CC..060204
MAC-F16-CC06L	MAC-F16-CC06R	●	●	90	16	8.5	13.5	46	28	CC..060204
MAC-L16-TC09L	MAC-L16-TC09R	●	●	95	16	8.5	13.5	46	28	TC..090204
MAC-F16-TC09L	MAC-F16-TC09R	●	●	90	16	8.5	13.5	46	28	TC..090204
MAC-L16-TP09L	MAC-L16-TP09R	●	●	95	16	8.5	13.5	46	28	TP..090204
MAC-F16-TP09L	MAC-F16-TP09R	●	●	90	16	8.5	13.5	46	28	TP..090204

● 常备库存 Unallocated stock    ● 可备库存 Available stock    ○ 订单生产 Order production

Inserts	刀片螺钉 Screw for insert	扳手 Wrench	径向调节螺钉 Screw for axial adjustment	刀座锁紧螺钉 Lock screw for cutting head	刀夹压紧螺钉 lock screw for cartridge	轴向调节螺钉 Screw for axial adjustment	楔块 Wedge	扳手 Wrench
CC..060204	SIC025065							
TC..090204	SIC022063	FT07	SMAC16A	SMAC16C	SCC050160	SKC050200	WMAC16	S2.5
TP..090204	SIC025065							

# C 孔加工刀具 Hole Making Tools

## MAC微调小刀夹 MAC Micro-adjustable Cartridge

适用于直径  $\phi 28\text{mm}$  及以上孔的精镗和半精镗加工 Fine boring and semi-finish boring hole with diameter  $\phi 28\text{mm}$  and above

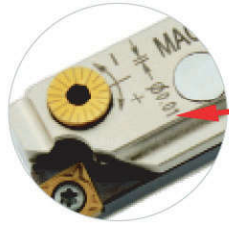

- 1 精度稳定，减少刀具调节时间，提高生产效率及产品质量
- 2 调节精度直径  $\phi 0.01\text{mm}/\text{div}$
- 3 轴向最大调节1mm，径向最大调节  $\phi 0.6\text{mm}$
- 4 刀夹带内部冷却，直接作用于切削刃
- 5 径向调节不会影响轴向位置



1. Stable precision, reduce the tool adjustment time, improve production efficiency and product quality
2. Adjustment accuracy  $\phi 0.01\text{mm} / \text{div}$ .
3. The maximum axial adjustment 1mm, radial maximum adjustment  $\phi 0.6\text{mm}$ .
4. Internal cooling, directly cooling the cutting edge.
5. Radial adjustment does not affect the axial position.

### MAC微调小刀夹安装尺寸 location for MAC micro-adjustable cartridge

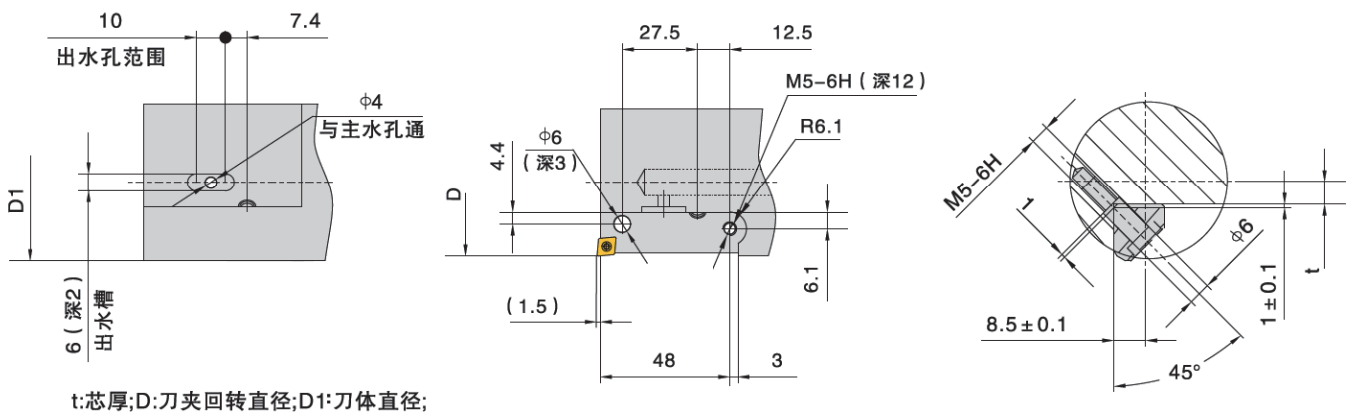

# C 孔加工刀具 Hole Making Tools

## MAC微调小刀夹 MAC Micro-adjustable Cartridge

### 刀夹尺寸调节指南 Adjusting steps for MAC micro-adjustable cartridge

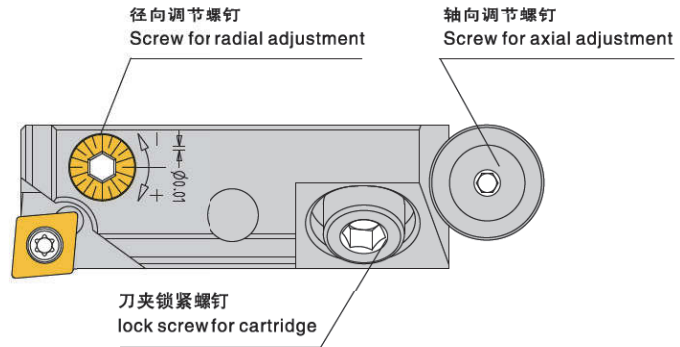

### 轴向尺寸调节: Adjustment in axial direction:

1. 微松刀夹锁紧螺钉，保持一定预紧力
  2. 旋转轴向调节螺钉，调节刀夹轴向位置，旋紧刀夹锁紧螺钉。
1. Loose the lock screw for cartridge lightly, keep enough pre-lock.
  2. Turn screw for axial adjustment, get the require position of insert, and then tighten the lock screw for cartridge.

### 径向尺寸调节: Radial adjustment:

1. 顺时针旋转径向调节螺钉，刀具直径变大
  2. 逆时针旋转径向调节螺钉，刀具直径变小
1. Turn the screw for radial adjustment clockwise, machine big diameter hole
  2. Turn the screw for radial adjustment counter-clockwise, cutter diameter smaller.

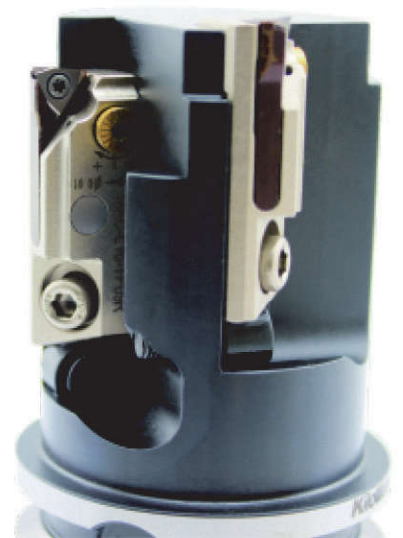

# C 孔加工刀具 Hole Making Tools

## TQC镗刀头 TQC Boring Head

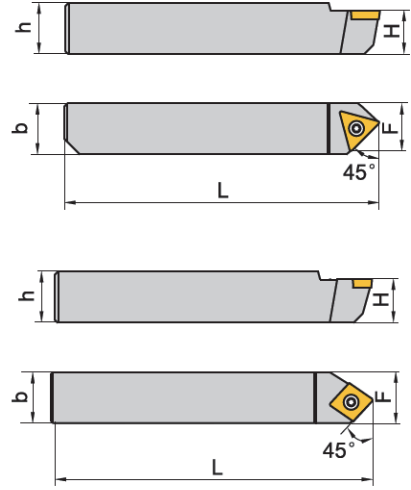

图示为L型

刀片 Inserts	螺钉 Screw	扳手 Wrench
CP..050204	SIC022063	FT07
TC..090204	SIC022063	FT07
TC..110204	SIC025065	FT07
CC..09T308	SIC035080	FT15
TC..16T308	SIC035080	FT15
CC..120408	SID040110	FT15

型号 Type	库存 Stock	镗孔直径 Boring dia.	尺寸(mm) Dimension					刀片 Inserts	重量 (kg)
			h	b	H	F	L		
TQC08-29-45L	●	25-38	8	8	7	7.5	29	CP..050204	0.01
TQC08-45-45L	●	38-50	8	8	7	7.5	45	CP..050204	0.02
TQC10-45-45L	●	38-50	10	10	8	9.5	45	TC..090204	0.03
TQC10-60-45L	●	50-70	10	10	8	9.5	60	TC..090204	0.05
TQC13-60-45L	●	50-70	13	13	11	12.5	60	TC..110204	0.07
TQC13-81-45L	●	70-90	13	13	11	12.5	81	TC..110204	0.1
TQC13-60-45L.CC09	●	50-70	13	13	11	12.5	60	CC..09T308	0.1
TQC13-81-45L.CC09	●	70-90	13	13	11	12.5	81	CC..09T308	0.1
TQC16-75-45L	●	62-90	16	16	13	15.5	75	TC..110204	0.1
TQC16-105-45L	●	90-115	16	16	13	15.5	105	TC..110204	0.17
TQC16-75-45L.CC09	●	62-90	16	16	13	15.5	75	CC..09T308	0.1
TQC16-105-45L.CC09	●	90-115	16	16	13	15.5	105	CC..09T308	0.17
TQC19-88-45L	●	72-105	19	19	15	18.5	88	TC..16T308	0.26
TQC19-119-45L	●	105-135	19	19	15	18.5	119	TC..16T308	0.35
TQC19-150-45L	●	135-150	19	19	15	18.5	150	TC..16T308	0.44
TQC19-88-45L.CC12	●	72-105	19	19	15	18.5	88	CC..120408	0.26
TQC19-119-45L.CC12	●	105-135	19	19	15	18.5	119	CC..120408	0.35
TQC19-150-45L.CC12	●	135-150	19	19	15	18.5	150	CC..120408	0.44
TQC25-125-45L	●	105-140	25	25	20	24.5	125	TC..16T308	0.55
TQC25-169-45L	●	140-190	25	25	20	24.5	169	TC..16T308	0.77
TQC25-125-45L.CC12	●	105-140	25	25	20	24.5	125	CC..120408	0.55
TQC25-169-45L.CC12	●	140-190	25	25	20	24.5	169	CC..120408	0.77

● 常备库存 Unallocated stock    ● 可备库存 Available stock    ○ 订单生产 Order production



# C 孔加工刀具 Hole Making Tools

## TZC镗刀头 TZC Boring Head

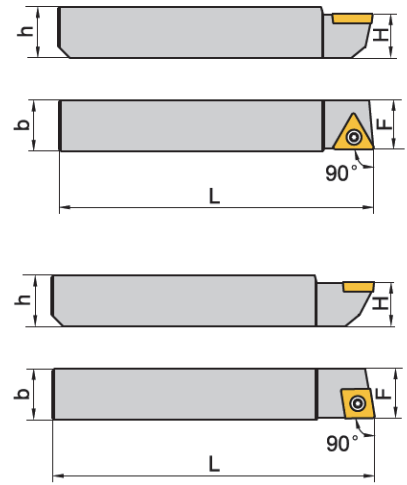

图示为L型

刀片 Inserts	螺钉 Screw 	扳手 Wrench 
CP..050204	SIC022063	FT07
TC..090204	SIC022063	FT07
TC..110204	SIC025065	FT07
CC..09T308	SIC035080	FT15
TC..16T308	SIC035080	FT15
CC..120408	SID040110	FT15

型号 Type	库存 Stock	镗孔直径 Boring dia.	尺寸(mm) Dimension					刀片 Inserts 	重量 (kg)
			h	b	H	F	L		
TZC08-23-90L	●	25-38	8	8	7	7.5	23	CP..050204	0.01
TZC08-36-90L	●	38-50	8	8	7	7.5	36	CP..050204	0.02
TZC10-36-90L	●	38-50	10	10	8	9.5	36	TC..090204	0.03
TZC10-48-90L	●	50-70	10	10	8	9.5	48	TC..090204	0.04
TZC13-48-90L	●	50-70	13	13	11	12.5	48	TC..110204	0.06
TZC13-65-90L	●	70-90	13	13	11	12.5	65	TC..110204	0.08
TZC13-48-90L.CC09	●	50-70	13	13	11	12.5	48	CC..09T308	0.06
TZC13-65-90L.CC09	●	70-90	13	13	11	12.5	65	CC..09T308	0.08
TZC16-60-90L	●	62-90	16	16	13	15.5	60	TC..110204	0.13
TZC16-85-90L	●	90-115	16	16	13	15.5	85	TC..110204	0.18
TZC16-60-90L.CC09	●	62-90	16	16	13	15.5	60	CC..09T308	0.13
TZC16-85-90L.CC09	●	90-115	16	16	13	15.5	85	CC..09T308	0.18
TZC19-70-90L	●	72-105	19	19	15	18.5	70	TC..16T308	0.2
TZC19-95-90L	●	105-135	19	19	15	18.5	95	TC..16T308	0.27
TZC19-120-90L	●	135-150	19	19	15	18.5	120	TC..16T308	0.37
TZC19-70-90L.CC12	●	72-105	19	19	15	18.5	70	CC..120408	0.2
TZC19-95-90L.CC12	●	105-135	19	19	15	18.5	95	CC..120408	0.27
TZC19-120-90L.CC12	●	135-150	19	19	15	18.5	120	CC..120408	0.37
TZC25-100-90L	●	105-140	25	25	20	24.5	100	TC..16T308	0.43
TZC25-135-90L	●	140-190	25	25	20	24.5	135	TC..16T308	0.6
TZC25-100-90L.CC12	●	105-140	25	25	20	24.5	100	CC..120408	0.43
TZC25-135-90L.CC12	●	140-190	25	25	20	24.5	135	CC..120408	0.6

● 常备库存  
Unallocated stock

◐ 可备库存  
Available stock

○ 订单生产  
Order production

# C 孔加工刀具 Hole Making Tools

M..FNR/L 90°小刀夹  
M..FNR/L 90° Cartridge

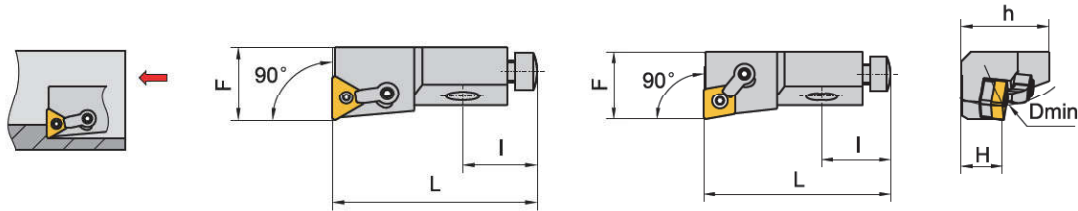
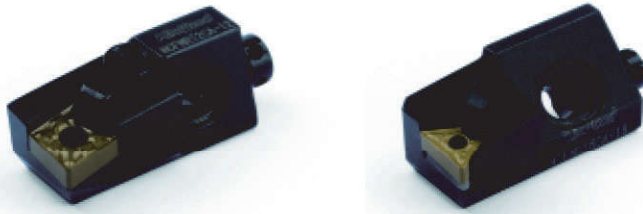

型号 Type		库存 Stock		刀片 Inserts	尺寸(mm) Dimension						重量 (kg)
左刀 Left hand	右刀 Right hand	L	R		H	F	h	I	L	Dmin	
MCFNL10CA-09	MCFNR10CA-09	○	●	CN..090308	10	14	15	20	50	40	0.06
MCFNL12CA-09	MCFNR12CA-09	○	○	CN..090308	12	20	20	20	55	50	0.11
MCFNL12CA-12	MCFNR12CA-12	○	●	CN..120408	12	20	20	20	55	50	0.11
MCFNL16CA-12	MCFNR16CA-12	○	○	CN..120408	16	25	25	25	63	60	0.20
MCFNL20CA-12	MCFNR20CA-12	○	●	CN..120408	20	25	25	30	70	70	0.25
MTFNL12CA-16	MTFNR12CA-16	●	●	TN..160408	12	20	20	20	55	50	0.11
MTFNL16CA-16	MTFNR16CA-16	○	●	TN..160408	16	25	25	25	63	60	0.20
MTFNL20CA-22	MTFNR20CA-22	○	●	TN..220408	20	25	25	30	70	70	0.25
MTFNL25CA-27	MTFNR25CA-27	○	○	TN..270612	25	32	32	30	100	100	0.36

● 常备库存 Unallocated stock    ● 可备库存 Available stock    ○ 订单生产 Order production

## 备件 / SPARE PARTS

刀片 Inserts	刀垫 Shim	销钉 Lock pin	扳手 Wrench	压板 Clamp	双头螺栓 Clamp screw	扳手 Wrench
CN..090308(10CA/12CA)	-	NL-33	S5/64	CL-6	XNS-36	S3/32
CN..120408(12CA)	-	NL-44	S3/32	CL-20	XNS-48	S1/8
CN..120408(16CA/20CA)	ICSN-433	NL-46	S3/32	CL-20	XNS-48	S1/8
TN..160408(12CA)	-	NL-33L	S5/64	CL-6	XNS-36	S3/32
TN..160408(16CA)	ITSN-323	NL-34L	S5/64	CL-6	XNS-36	S3/32
TN..220408(20CA)	ITSN-433	NL-46	S3/32	CL-9	XNS-59	S5/32
TN..270612(25CA)	ITSN-534	NL-58	S1/8	CL-12	XNS-510	S5/32

# C 孔加工刀具 Hole Making Tools

MTGNR/L 90°小刀夹  
MTGNR/L 90° Cartridge

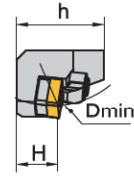
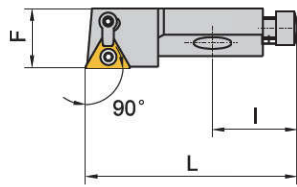
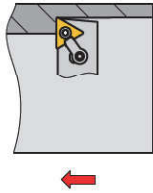

型号 Type		库存 Stock		刀片 Inserts	尺寸(mm) Dimension						重量 (kg)
左刀 Left hand	右刀 Right hand	L	R		H	F	h	I	L	Dmin	
MTGNL12CA-16	MTGNR12CA-16	●	●	TN..160408	12	20	20	20	55	50	0.11
MTGNL20CA-22	MTGNR20CA-22	○	○	TN..220408	20	25	25	30	70	70	0.25
MTGNL25CA-27	MTGNR25CA-27	○	○	TN..270612	25	32	32	30	100	100	0.36

● 常备库存  
Unallocated stock

◐ 可备库存  
Available stock

○ 订单生产  
Order production

## 备件 / SPARE PARTS

刀片 Inserts	刀垫 Shim	销钉 Lock pin	扳手 Wrench	压板 Clamp	双头螺栓 Clamp screw	扳手 Wrench
TN..160408(12CA)	-	NL-33L	S5/64	CL-6	XNS-36	S3/32
TN..220408(20CA)	ITSN-433	NL-46	S3/32	CL-9	XNS-59	S5/32
TN..270612(25CA)	ITSN-534	NL-58	S1/8	CL-12	XNS-510	S5/32

# C 孔加工刀具 Hole Making Tools

M..KNR/L 75°小刀夹  
M..KNR/L 75° Cartridge

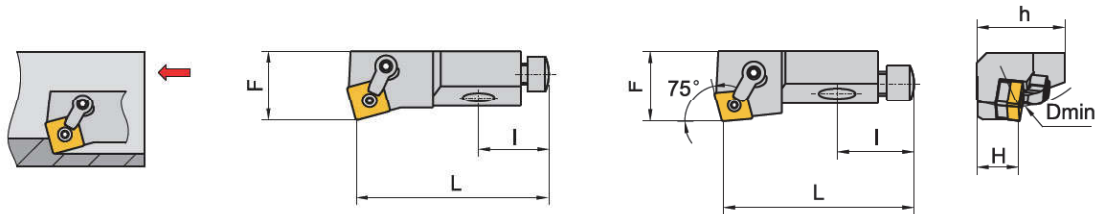

孔加工刀具

ROUGH BORING  
粗镗用刀具

FINISH BORING  
精镗用刀具

BORING UNIT  
镗削单元

型号 Type		库存 Stock		刀片 Inserts	尺寸(mm) Dimension						重量 (kg)
左刀 Left hand	右刀 Right hand	L	R		H	F	h	I	L	Dmin	
MCKNL12CA-12	MCKNR12CA-12	○	○	CN..120408	12	20	20	20	55	50	0.11
MCKNL16CA-12	MCKNR16CA-12	○	○	CN..120408	16	25	25	25	63	60	0.20
MCKNL20CA-12	MCKNR20CA-12	○	○	CN..120408	20	25	25	30	70	70	0.25
MSKNL10CA-09	MSKNR10CA-09	○	●	SN..090308	10	14	15	20	50	40	0.06
MSKNL12CA-12	MSKNR12CA-12	○	●	SN..120408	12	20	20	20	55	50	0.11
MSKNL16CA-12	MSKNR16CA-12	○	●	SN..120408	16	25	25	25	63	60	0.20
MSKNL20CA-15	MSKNR20CA-15	○	●	SN..150612	20	25	25	30	70	70	0.25
MSKNL25CA-19	MSKNR25CA-19	○	○	SN..190612	25	32	32	30	100	100	0.36

● 常备库存  
Unallocated stock

◐ 可备库存  
Available stock

○ 订单生产  
Order production

## 备件 / SPARE PARTS

刀片 Inserts	刀垫 Shim	销钉 Lock pin	扳手 Wrench	压板 Clamp	双头螺栓 Clamp screw	扳手 Wrench
CN..120408(12CA)	-	NL-44	S3/32	CL-20	XNS-48	S1/8
CN..120408(16CA/20CA)	ICSN-433	NL-46	S3/32	CL-20	XNS-48	S1/8
SN..090308(10CA)	-	NL-33	S5/64	CL-6	XNS-36	S3/32
SN..120408(12CA)	-	NL-44	S3/32	CL-6	XNS-36	S3/32
SN..120408(16CA)	ISSN-433	NL-46	S3/32	CL-9	XNS-59	S5/32
SN..150612(20CA)	ISSN-533	NL-58	S1/8	CL-12	XNS-510	S5/32
SN..190612(25CA)	ISSN-633	NL-68	S9/64	CL-12	XNS-510	S5/32

# C 孔加工刀具 Hole Making Tools



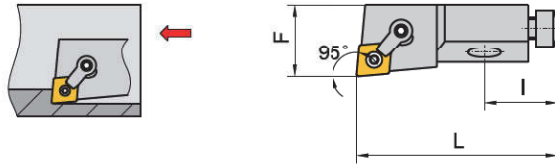



MCLNR/L 95°小刀夹  
MCLNR/L 95° Cartridge



型号 Type		库存 Stock		刀片 Inserts 	尺寸(mm) Dimension						重量 (kg)
左刀 Left hand	右刀 Right hand	L	R		H	F	h	I	L	Dmin	
MCLNL12CA-12	MCLNR12CA-12	○	●	CN..120408	12	20	20	20	55	50	0.11
MCLNL16CA-12	MCLNR16CA-12	○	○	CN..120408	16	25	25	25	63	60	0.20
MCLNL20CA-12	MCLNR20CA-12	○	○	CN..120408	20	25	25	30	70	70	0.25
MCLNL25CA-19	MCLNR25CA-19	○	○	CN..190612	25	32	32	30	100	100	0.36

● 常备库存 Unallocated stock    ● 可备库存 Available stock    ○ 订单生产 Order production

## 备件 / SPARE PARTS

刀片 Inserts	刀垫 Shim 	销钉 Lock pin 	扳手 Wrench 	压板 Clamp 	双头螺栓 Clamp screw 	扳手 Wrench 
CN..120408(12CA)	-	NL-44	S3/32	CL-20	XNS-48	S1/8
CN..120408(16CA/20CA)	ICSN-433	NL-46	S3/32	CL-20	XNS-48	S1/8
CN..190612(25CA)	ICSN-633	NL-68	S9/64	CL-12	XNS-510	S5/32

# C 孔加工刀具 Hole Making Tools

MSRNR/L 75°小刀夹  
MSRNR/L 75° Cartridge

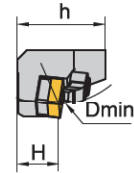
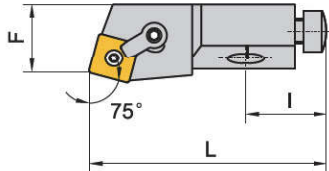
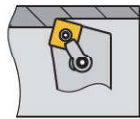

孔加工刀具

ROUGH BORING  
粗镗用刀具







FINISH BORING  
精镗用刀具

BORING UNIT  
镗削单元

型号 Type		库存 Stock		刀片 Inserts 	尺寸(mm) Dimension						重量 (kg)
左刀 Left hand	右刀 Right hand	L	R		H	F	h	I	L	Dmin	
MSRNL10CA-09	MSRNR10CA-09	●	●	SN..090308	10	14	15	20	50	40	0.06
MSRNL12CA-12	MSRNR12CA-12	●	○	SN..120408	12	20	20	20	55	50	0.11
MSRNL16CA-12	MSRNR16CA-12	●	●	SN..120408	16	25	25	25	63	60	0.20
MSRNL20CA-15	MSRNR20CA-15	○	●	SN..150612	20	25	25	30	70	70	0.25

● 常备库存 Unallocated stock    ● 可备库存 Available stock    ○ 订单生产 Order production

## 备件 / SPARE PARTS

刀片 Inserts	刀垫 Shim 	销钉 Lock pin 	扳手 Wrench 	压板 Clamp 	双头螺栓 Clamp screw 	扳手 Wrench 
SN..090308(10CA)	-	NL-33	S5/64	CL-6	XNS-36	S3/32
SN..120408(12CA)	-	NL-44	S3/32	CL-9	XNS-59	S5/32
SN..120408(16CA)	ISSN-433	NL-46	S3/32	CL-9	XNS-59	S5/32
SN..150612(20CA)	ISSN-533	NL-58	S1/8	CL-9	XNS-510	S5/32



# C 孔加工刀具 Hole Making Tools



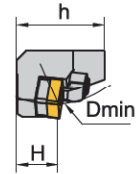
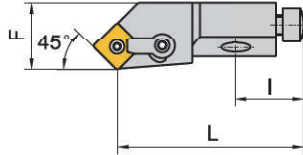
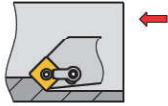



MSSNR/L 45°小刀夹  
MSSNR/L 45° Cartridge



型号 Type		库存 Stock		刀片 Inserts 	尺寸(mm) Dimension						重量 (kg)
左刀 Left hand	右刀 Right hand	L	R		H	F	h	I	L	Dmin	
MSSNL10CA-09	MSSNR10CA-09	○	●	SN..090308	10	14	15	20	44	40	0.06
MSSNL12CA-12	MSSNR12CA-12	○	●	SN..120408	12	20	20	20	47	50	0.11
MSSNL16CA-12	MSSNR16CA-12	○	○	SN..120408	16	25	25	25	53	60	0.25
MSSNL20CA-15	MSSNR20CA-15	○	●	SN..150612	20	25	25	30	60	70	0.25

● 常备库存 Unallocated stock    ◐ 可备库存 Available stock    ○ 订单生产 Order production

## 备件 / SPARE PARTS

刀片 Inserts	刀垫 Shim 	销钉 Lock pin 	扳手 Wrench 	压板 Clamp 	双头螺栓 Clamp screw 	扳手 Wrench 
SN..090308(10CA)	-	NL-33	S5/64	CL-6	XNS-36	S3/32
SN..120408(12CA)	-	NL-44	S3/32	CL-9	XNS-59	S5/32
SN..120408(16CA)	ISSN-433	NL-46	S3/32	CL-9	XNS-59	S5/32
SN..150612(20CA)	ISSN-533	NL-58	S1/8	CL-9	XNS-59	S5/32

# C 孔加工刀具 Hole Making Tools

MSTNR/L 60°小刀夹  
MSTNR/L 60° Cartridge

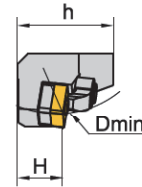
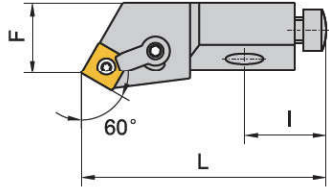
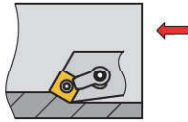

孔加工刀具

ROUGH BORING  
粗镗用刀具

FINISH BORING  
精镗用刀具

BORING UNIT  
镗削单元







型号 Type		库存 Stock		刀片 Inserts 	尺寸(mm) Dimension						重量 (kg)
左刀 Left hand	右刀 Right hand	L	R		H	F	h	I	L	Dmin	
MSTNL10CA-09	MSTNR10CA-09	●	○	SN..090308	10	9	15	20	50	40	0.06
MSTNL12CA-12	MSTNR12CA-12	○	●	SN..120408	12	13	20	20	55	50	0.11
MSTNL16CA-12	MSTNR16CA-12	○	○	SN..120408	16	15	25	25	63	60	0.20

● 常备库存  
Unallocated stock

◐ 可备库存  
Available stock

○ 订单生产  
Order production

## 备件 / SPARE PARTS

刀片 Inserts	刀垫 Shim 	销钉 Lock pin 	扳手 Wrench 	压板 Clamp 	双头螺栓 Clamp screw 	扳手 Wrench 
SN..090308(10CA)	-	NL-33	S5/64	CL-6	XNS-36	S3/32
SN..120408(12CA)	-	NL-44	S3/32	CL-9	XNS-59	S5/32
SN..120408(16CA)	ISSN-433	NL-46	S3/32	CL-9	XNS-59	S5/32

# C 孔加工刀具 Hole Making Tools

S..F..R/L 90°小刀夹  
S..F..R/L 90° Cartridge

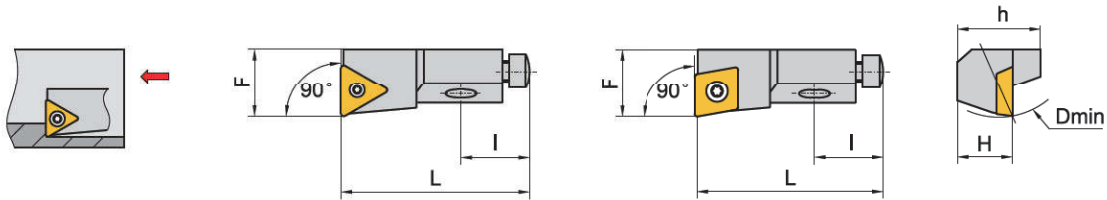
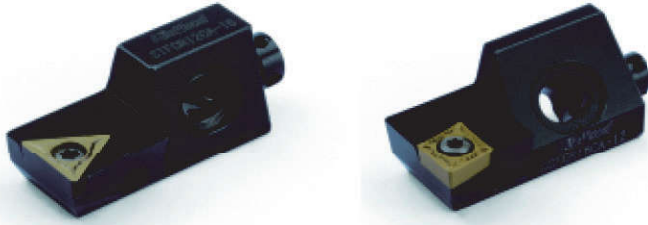

型号 Type		库存 Stock		刀片 Inserts	尺寸(mm) Dimension						重量 (kg)
左刀 Left hand	右刀 Right hand	L	R		H	F	h	I	L	Dmin	
SCFPL06CA-05	SCFPR06CA-05	○	○	CP..050204	6	8	8.5	12	25	20	0.03
SCFCL08CA-06	SCFCR08CA-06	●	●	CC..060204	8	10	11	17	32	25	0.04
SCFCL10CA-09	SCFCR10CA-09	●	●	CC..09T308	10	14	15	20	50	40	0.07
SCFCL12CA-09	SCFCR12CA-09	○	●	CC..09T308	12	20	20	20	55	50	0.11
SCFCL12CA-12	SCFCR12CA-12	●	●	CC..120408	12	20	20	20	55	50	0.11
SCFCL16CA-12	SCFCR16CA-12	●	●	CC..120408	16	25	25	25	63	60	0.15
STFCL08CA-09	STFCR08CA-09	●	●	TC..090204	8	10	11	17	32	25	0.04
STFCL10CA-11	STFCR10CA-11	●	●	TC..110204	10	14	15	20	50	40	0.07
STFCL12CA-16	STFCR12CA-16	●	●	TC..16T308	12	20	20	20	55	50	0.11
STFCL16CA-16	STFCR16CA-16	○	●	TC..16T308	16	25	25	25	63	60	0.15

● 常备库存 Unallocated stock    ◐ 可备库存 Available stock    ○ 订单生产 Order production

## 备件 / SPARE PARTS

刀片 Inserts	螺钉 Screw	扳手 Wrench
CP..050204	SIC022063	FT07
CC..060204	SIC025065	FT07
CC..09T308	SIC035080	FT15
CC..120408	SID040110	FT15
TC..090204	SIC022063	FT07
TC..110204	SIC025065	FT07
TC..16T308	SIC035080	FT15

# C 孔加工刀具 Hole Making Tools

S..G..R/L 90°小刀夹  
S..G..R/L 90° Cartridge

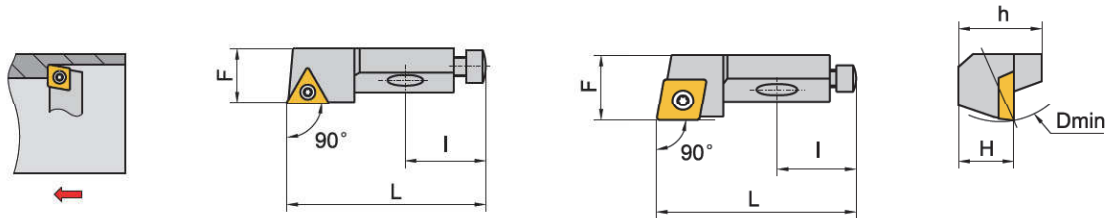
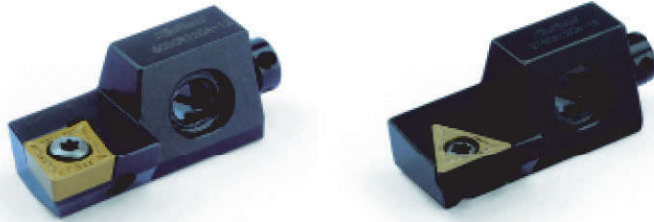

型号 Type		库存 Stock		刀片 Inserts	尺寸(mm) Dimension						重量 (kg)
左刀 Left hand	右刀 Right hand	L	R	 	H	F	h	I	L	Dmin	
SCGPL06CA-05	SCGPR06CA-05	○	○	CP..050204	6	8	8.5	12	25	20	0.03
SCGCL08CA-06	SCGCR08CA-06	●	●	CC..060204	8	10	11	17	32	25	0.04
SCGCL10CA-09	SCGCR10CA-09	●	●	CC..09T308	10	14	15	20	50	40	0.07
SCGCL12CA-09	SCGCR12CA-09	●	●	CC..09T308	12	20	20	20	55	50	0.11
SCGCL12CA-12	SCGCR12CA-12	●	●	CC..120408	12	20	20	20	55	50	0.11
SCGCL16CA-12	SCGCR16CA-12	●	●	CC..120408	16	25	25	25	63	60	0.15
STGCL08CA-09	STGCR08CA-09	○	●	TC..090204	8	10	11	17	32	25	0.04
STGCL10CA-11	STGCR10CA-11	●	●	TC..110204	10	14	15	20	50	40	0.07
STGCL12CA-16	STGCR12CA-16	●	●	TC..16T308	12	20	20	20	55	50	0.11
STGCL16CA-16	STGCR16CA-16	●	●	TC..16T308	16	25	25	25	63	60	0.15

● 常备库存 Unallocated stock    ◐ 可备库存 Available stock    ○ 订单生产 Order production

## 备件 / SPARE PARTS

刀片 Inserts	螺钉 Screw 	扳手 Wrench 
CP..050204	SIC022063	FT07
CC..060204	SIC025065	FT07
CC..09T308	SIC035080	FT15
CC..120408	SID040110	FT15
TC..090204	SIC022063	FT07
TC..110204	SIC025065	FT07
TC..16T308	SIC035080	FT15

# C 孔加工刀具 Hole Making Tools

S..K..R/L 75°小刀夹  
S..K..R/L 75° Cartridge

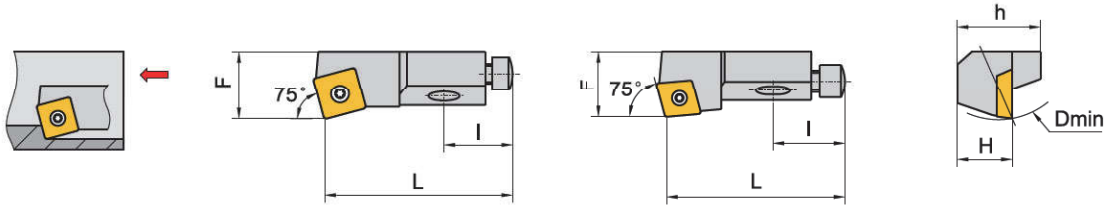
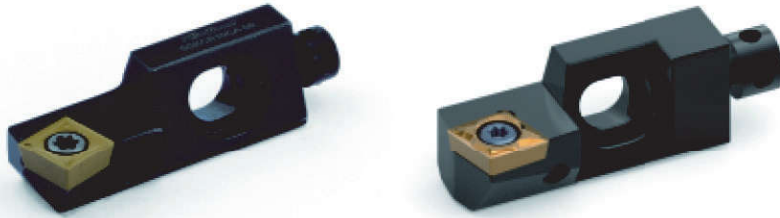

型号 Type		库存 Stock		刀片 Inserts	尺寸(mm) Dimension						重量 (kg)
左刀 Left hand	右刀 Right hand	L	R		H	F	h	I	L	Dmin	
SCKPL06CA-05	SCKPR06CA-05	○	○	CP..050204	6	8	8.5	12	25	20	0.03
SCKCL08CA-06	SCKCR08CA-06	●	●	CC..060204	8	10	11	17	32	25	0.04
SSKCL10CA-09	SSKCR10CA-09	●	●	SC..09T308	10	14	15	20	50	40	0.07
SSKCL12CA-09	SSKCR12CA-09	○	●	SC..09T308	12	20	20	20	55	50	0.11
SSKCL12CA-12	SSKCR12CA-12	●	●	SC..120408	12	20	20	20	55	50	0.11
SSKCL16CA-12	SSKCR16CA-12	●	●	SC..120408	16	25	25	25	63	60	0.15

● 常备库存 Unallocated stock    ● 可备库存 Available stock    ○ 订单生产 Order production

## 备件 / SPARE PARTS

刀片 Inserts	螺钉 Screw	扳手 Wrench
CP..050204	SIC022063	FT07
CC..060204	SIC025065	FT07
SC..09T308	SIC035080	FT15
SC..120408	SID040110	FT15

# C 孔加工刀具 Hole Making Tools

SCL..R/L 95°小刀夹  
SCL..R/L 95° Cartridge

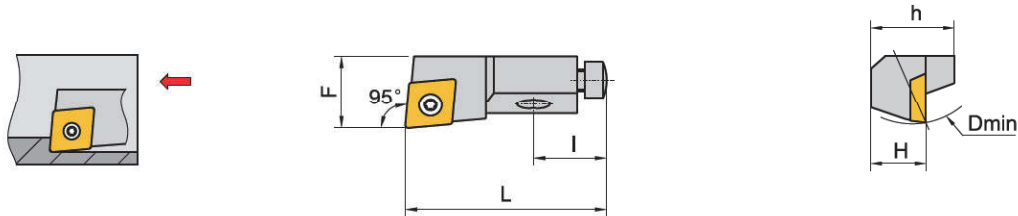

孔加工刀具

ROUGH BORING  
粗镗用刀具

FINISH BORING  
精镗用刀具

BORING UNIT  
镗削单元

型号 Type		库存 Stock		刀片 Inserts	尺寸(mm) Dimension						重量 (kg)
左刀 Left hand	右刀 Right hand	L	R		H	F	h	I	L	Dmin	
SCLPL06CA-05	SCLPR06CA-05	○	○	CP..050204	6	8	8.5	12	25	20	0.03
SCLCL08CA-06	SCLCR08CA-06	●	●	CC..060204	8	10	11	17	32	25	0.04
SCLCL10CA-09	SCLCR10CA-09	●	●	CC..09T308	10	14	15	20	50	40	0.07
SCLCL12CA-12	SCLCR12CA-12	●	●	CC..120408	12	20	20	20	55	50	0.11

● 常备库存 Unallocated stock    ● 可备库存 Available stock    ○ 订单生产 Order production

## 备件 / SPARE PARTS

刀片 Inserts	螺钉 Screw	扳手 Wrench
CP..050204	SIC022063	FT07
CC..060204	SIC025065	FT07
CC..09T308	SIC035080	FT15
CC..120408	SID040110	FT15



# C 孔加工刀具 Hole Making Tools

SC..R/L 75°小刀夹  
SC..R/L 75° Cartridge

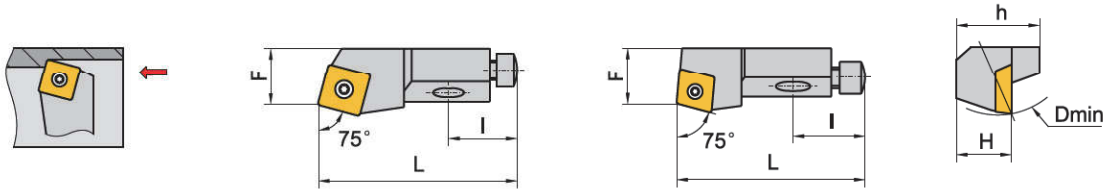
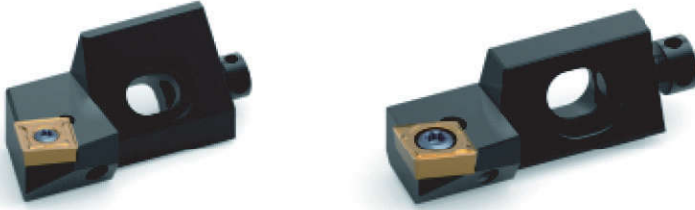

型号 Type		库存 Stock		刀片 Inserts	尺寸(mm) Dimension						重量 (kg)
左刀 Left hand	右刀 Right hand	L	R		H	F	h	I	L	Dmin	
SCRPL06CA-05	SCRPR06CA-05	○	●	CP..050204	6	8	8.5	12	25	20	0.03
SCRCL08CA-06	SCRCR08CA-06	○	●	CC..060204	8	10	11	17	32	25	0.04
SCRCL10CA-09	SCRRCR10CA-09	○	○	CC..09T308	10	14	15	20	50	40	0.07
SSRCL10CA-09	SSRCR10CA-09	○	●	SC..09T308	10	14	15	20	50	40	0.07
SSRCL12CA-09	SSRCR12CA-09	●	○	SC..09T308	12	20	20	20	55	50	0.11
SSRCL12CA-12	SSRCR12CA-12	●	●	SC..120408	12	20	20	20	55	50	0.11
SSRCL16CA-12	SSRCR16CA-12	●	●	SC..120408	16	25	25	25	63	60	0.15

● 常备库存 Unallocated stock    ● 可备库存 Available stock    ○ 订单生产 Order production

## 备件 / SPARE PARTS

刀片 Inserts	螺钉 Screw	扳手 Wrench
CP..050204	SIC022063	FT07
CC..060204	SIC025065	FT07
CC..09T308	SIC035080	FT15
SC..09T308	SIC035080	FT15
SC..120408	SID040110	FT15

# C 孔加工刀具 Hole Making Tools

S..S..R/L 45°小刀夹  
S..S..R/L 45° Cartridge

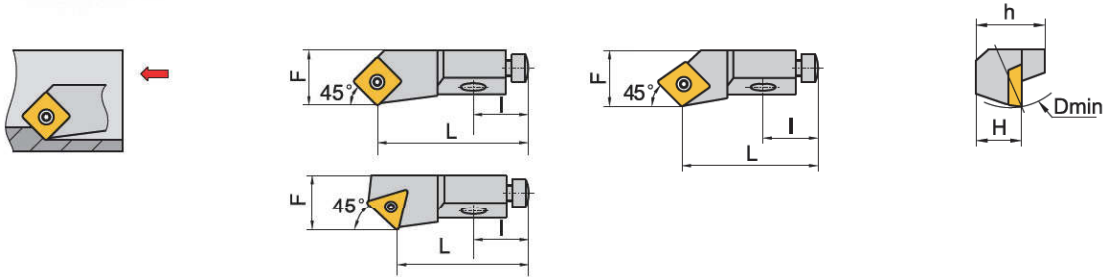
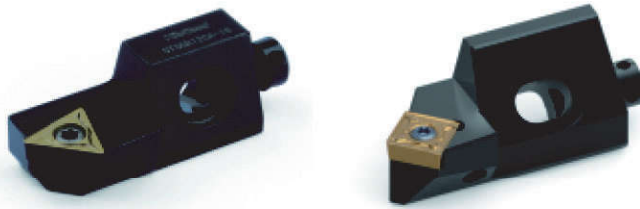

孔加工刀具

ROUGH BORING  
粗镗用刀具

FINISH BORING  
精镗用刀具

BORING UNIT  
镗削单元

型号 Type		库存 Stock		刀片 Inserts	尺寸(mm) Dimension						重量 (kg)
左刀 Left hand	右刀 Right hand	L	R		H	F	h	I	L	Dmin	
SCSPL06CA-05	SCSPR06CA-05	○	●	CP..050204	6	8	8.5	12	21	20	0.03
SCSCL08CA-06	SCSCR08CA-06	●	●	CC..060204	8	10	11	17	28	25	0.04
STSCL08CA-09	STSCR08CA-09	○	●	TC..090204	8	10	11	17	28	25	0.04
SCSCL10CA-09	SCSCR10CA-09	○	●	CC..09T308	10	14	15	20	44	40	0.07
SSSCL10CA-09	SSSCR10CA-09	●	●	SC..09T308	10	14	15	20	44	40	0.07
STSCL10CA-11	STSCR10CA-11	○	●	TC..110204	10	14	15	20	44	40	0.07
SSSCL12CA-09	SSSCR12CA-09	●	●	SC..09T308	12	20	20	20	47	50	0.11
SSSCL12CA-12	SSSCR12CA-12	●	●	SC..120408	12	20	20	20	47	50	0.11
STSCL12CA-16	STSCR12CA-16	●	●	TC..16T308	12	20	20	20	47	50	0.11
SSSCL16CA-12	SSSCR16CA-12	○	●	SC..120408	16	25	25	25	53	60	0.15
STSCL16CA-16	STSCR16CA-16	○	●	TC..16T308	16	25	25	25	53	60	0.15

● 常备库存  
Unallocated stock

◐ 可备库存  
Available stock

○ 订单生产  
Order production

## 备件 / SPARE PARTS

刀片 Inserts	螺钉 Screw 	扳手 Wrench 
CP..050204	SIC022063	FT07
CC..060204	SIC025065	FT07
TC..090204	SIC022063	FT07
CC..09T308	SIC035080	FT15
SC..09T308	SIC035080	FT15
TC..110204	SIC025065	FT07
SC..120408	SID040110	FT15
TC..16T308	SIC035080	FT15

# C 孔加工刀具 Hole Making Tools

S..T..R/L 60°小刀夹  
S..T..R/L 60° Cartridge

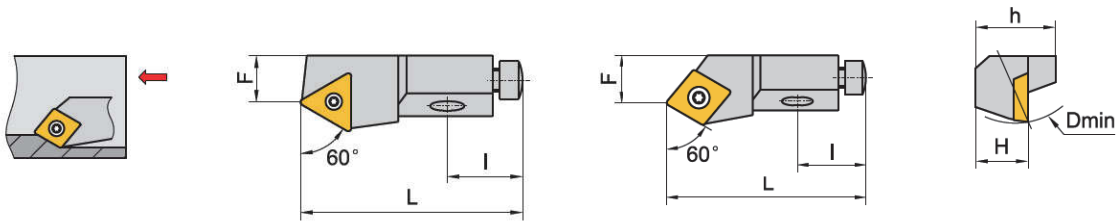
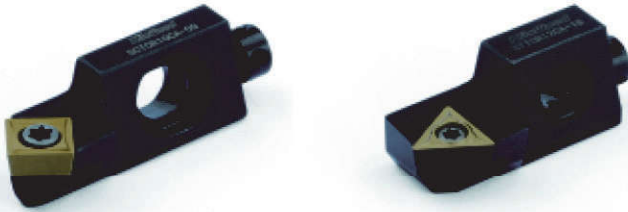

型号 Type		库存 Stock		刀片 Inserts	尺寸(mm) Dimension						重量 (kg)
左刀 Left hand	右刀 Right hand	L	R		H	F	h	I	L	Dmin	
SCTPL06CA-05	SCTPR06CA-05	●	○	CP..050204	6	5.5	8.5	12	25	20	0.03
SCTCL08CA-06	SCTCR08CA-06	●	●	CC..060204	8	6	11	17	32	25	0.04
SCTCL10CA-09	SCTCR10CA-09	●	●	CC..09T308	10	9	15	20	50	40	0.07
STTCL08CA-09	STTCR08CA-09	○	●	TC..090204	8	6	11	17	32	25	0.04
STTCL10CA-11	STTCR10CA-11	●	●	TC..110204	10	9	15	20	50	40	0.07
STTCL12CA-16	STTCR12CA-16	●	●	TC..16T308	12	13	20	20	55	50	0.11
STTCL16CA-16	STTCR16CA-16	○	○	TC..16T308	16	15	25	25	63	60	0.15

● 常备库存 Unallocated stock    ● 可备库存 Available stock    ○ 订单生产 Order production

## 备件 / SPARE PARTS

刀片 Inserts	螺钉 Screw	扳手 Wrench
CP..050204	SIC022063	FT07
CC..060204	SIC025065	FT07
CC..09T308	SIC035080	FT15
TC..090204	SIC022063	FT07
TC..110204	SIC025065	FT07
TC..16T308	SIC035080	FT15

# C 孔加工刀具 Hole Making Tools

S..W..R/L 60°小刀夹  
S..W..R/L 60° Cartridge

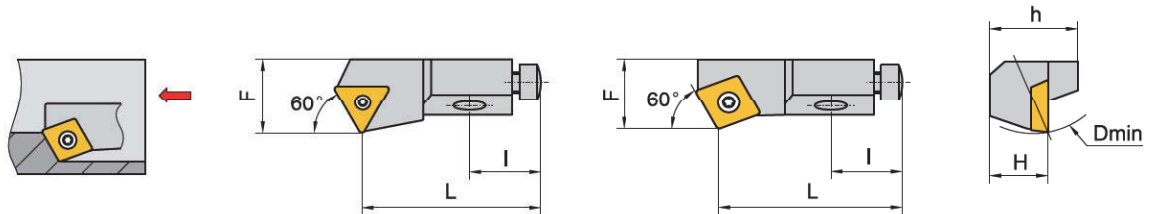
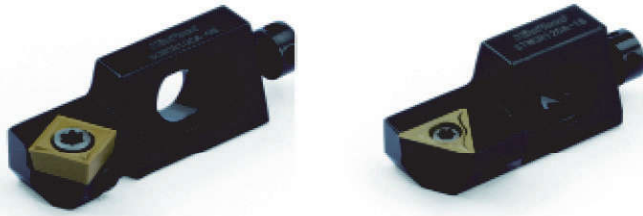

型号 Type		库存 Stock		刀片 Inserts	尺寸(mm) Dimension						重量 (kg)
左刀 Left hand	右刀 Right hand	L	R		H	F	h	I	L	Dmin	
SCWPL06CA-05	SCWPR06CA-05	○	●	CP..050204	6	8	8.5	12	21	20	0.03
SCWCL08CA-06	SCWCR08CA-06	○	○	CC..060204	8	10	11	17	28	25	0.04
SCWCL10CA-09	SCWCR10CA-09	○	●	CC..09T308	10	14	15	20	44	40	0.07
STWCL08CA-09	STWCR08CA-09	○	●	TC..090204	8	10	11	17	28	25	0.04
STWCL10CA-11	STWCR10CA-11	○	●	TC..110204	10	14	15	20	44	40	0.07
STWCL12CA-16	STWCR12CA-16	○	●	TC..16T308	12	20	20	20	47	50	0.11
STWCL16CA-16	STWCR16CA-16	○	○	TC..16T308	16	25	25	25	53	60	0.15

● 常备库存 Unallocated stock    ● 可备库存 Available stock    ○ 订单生产 Order production

## 备件 / SPARE PARTS

刀片 Inserts	螺钉 Screw	扳手 Wrench
CP..050204	SIC022063	FT07
CC..060204	SIC025065	FT07
CC..09T308	SIC035080	FT15
TC..090204	SIC022063	FT07
TC..110204	SIC025065	FT07
TC..16T308	SIC035080	FT15

# C 孔加工刀具 Hole Making Tools

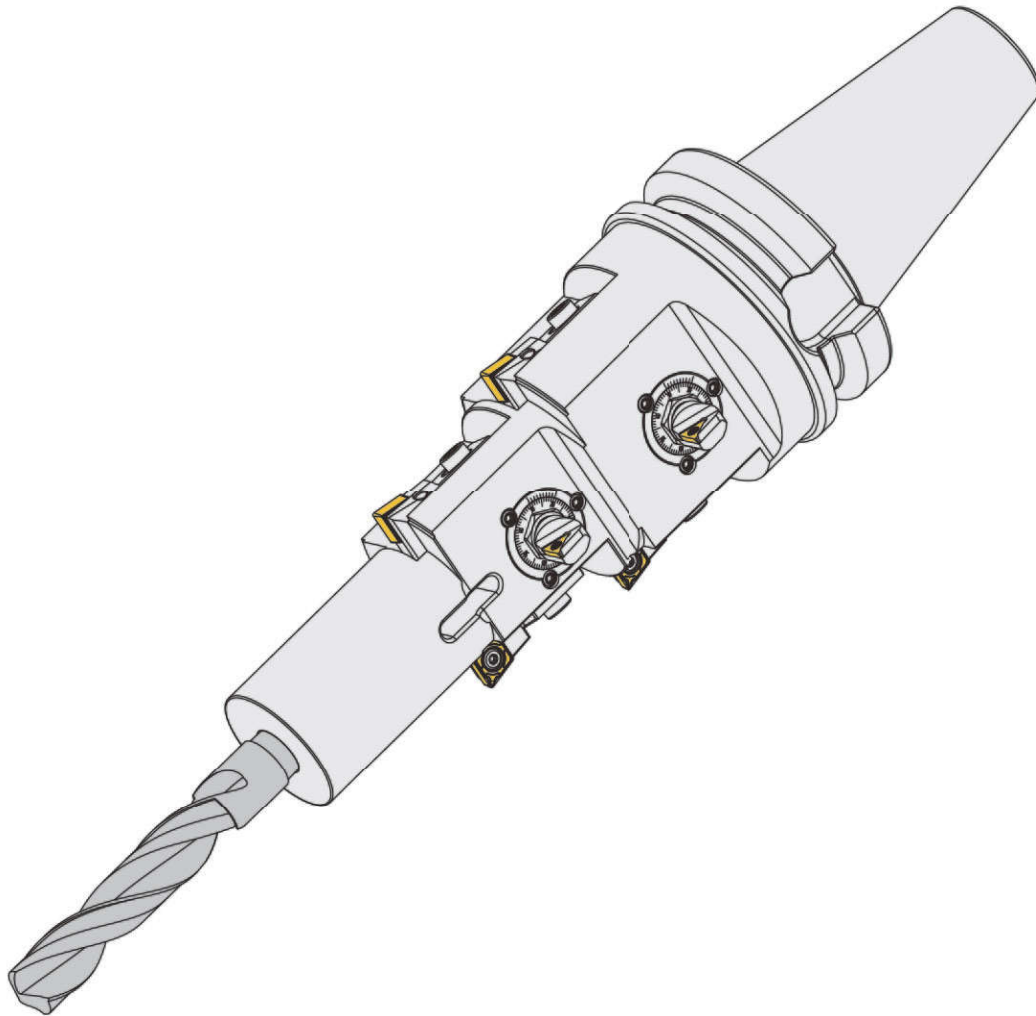





孔加工刀具

粗鑿用刀具  
ROUGH BORING

精鑿用刀具  
FINISH BORING

鑿削單元  
BORING UNIT

## 备件 / SPARE PARTS

刀夹型号 Cartridge type	螺钉 Screw 	扳手 Wrench 	螺钉 Screw 	螺钉 Screw 	扳手 Wrench 
06CA	SDC035120	S2.5	SAC030085	SSC030050	S1.5
08CA	SCC040160	S3	SAC040130	SSC030050	S1.5
10CA	SCC060200	S5	SAC050145	SSC040080	S2
12CA	SCC060250	S5	SAC060145	SSC050120	S2.5
16CA	SCC080350	S6	SAC060145	SSC060160	S3
20CA	SCC080350	S6	SAC060190	SSC060160	S3
25CA	SCC100400	S8	SAC060190	SSC060160	S3

# C 孔加工刀具 Hole Making Tools

## 刀夹安装示意图

### 径向安装

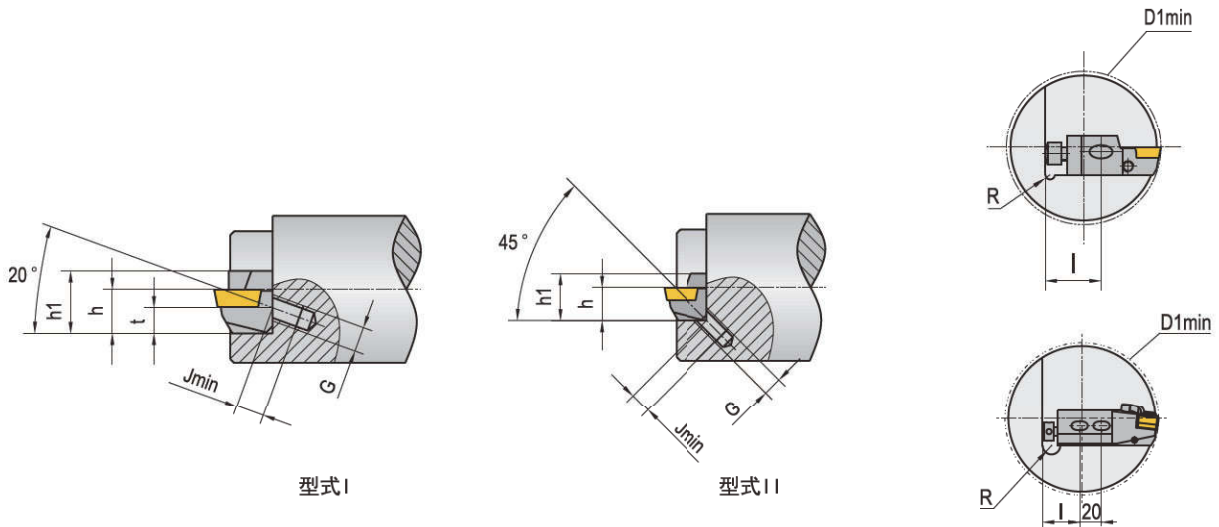

### 轴向安装

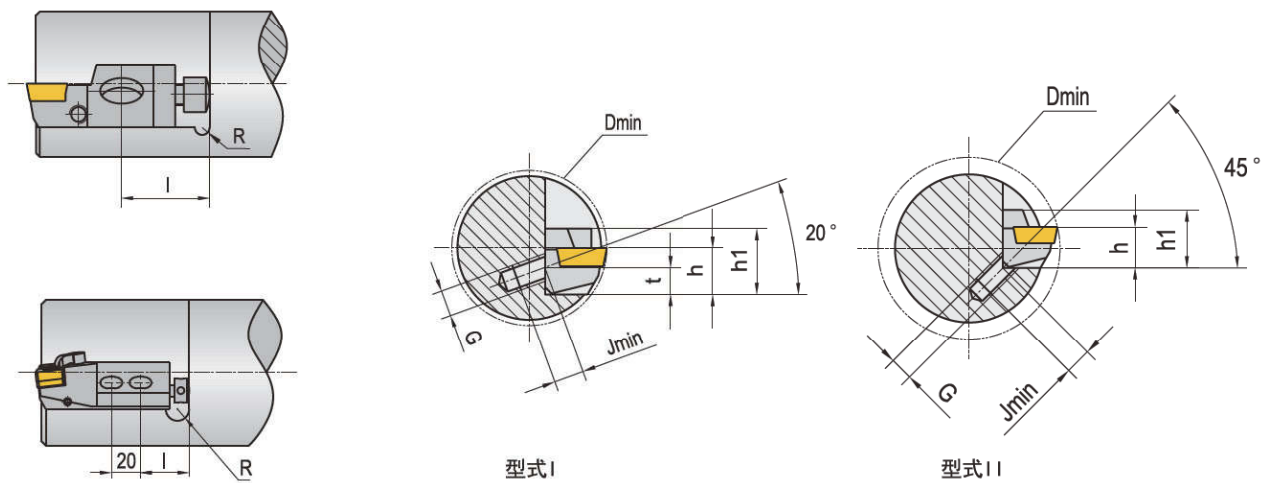

刀夹型号 Cartridge Type	h	I	G	Jmin	t	h1	Rmax	Dmin	D1min	型式 Model
06CA	6	12	M3.5X0.6	12	3.5	8.5	1.5	20	30	I
08CA	8	17	M4X0.7	17	4.5	10	2.5	25	36	I
10CA	10	20	M6X1	20	5	15	4	40	55	I
12CA	12	20	M6X1	20	6	20	5	50	75	I
16CA	16	25	M8X1.25	25	-	21	6	60	75	II
20CA	20	30	M8X1.25	25	-	30	6	70	90	II
25CA	25	30	M10X1.5	30	-	35	8	100	115	II



# C 孔加工刀具 Hole Making Tools

可接受以下各种组合非标刀具定制

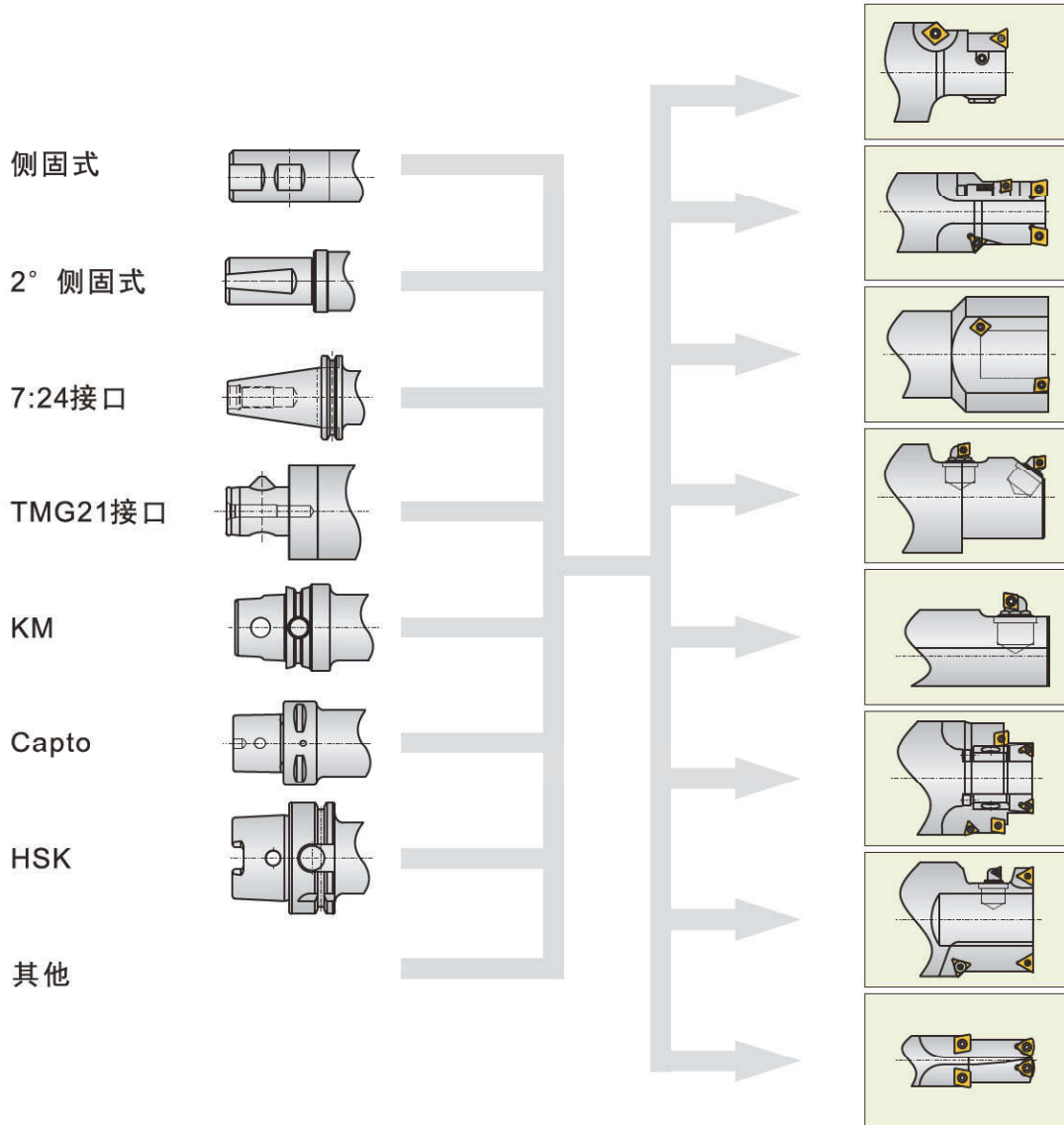

示例：

